

Microsoft®
SQL Server®

Licensing Guide



© 2009 Microsoft Corporation. All Rights Reserved. Microsoft, the Microsoft logo, Active Directory, BizTalk, Excel, Forefront, Hyper-V, Microsoft Dynamics, SQL Server, SharePoint, Windows, Windows Server, Windows Vista, and the Server Identity Logo are registered trademarks or trademarks of the Microsoft group of companies in the United States and/or other countries.

All other trademarks are property of their respective owners.

The example companies, organizations, products, domain names, e-mail addresses, logos, people, places, and events depicted herein are fictitious. No association with any real company, organization, product, domain name, e-mail address, logo, person, places, or events is intended or should be inferred.

This document is for informational purposes only. MICROSOFT MAKES NO WARRANTIES, EXPRESS OR IMPLIED, IN THIS SUMMARY.

Microsoft provides this material solely for informational and marketing purposes. Customers should refer to their agreements for a full understanding of their rights and obligations under Microsoft's Volume Licensing programs. Microsoft software is licensed not sold. The value and benefit gained through use of Microsoft software and services may vary by customer. Customers with questions about differences between this material and the agreements should contact their reseller or Microsoft account manager. Microsoft does not set final prices or payment terms for licenses acquired through resellers. Final prices and payment terms are determined by agreement between the customer and its reseller. Eligibility for Software Assurance benefits varies by offering and region and is subject to change. The Terms and Conditions of your Volume License Agreement and the Terms and Conditions under which any specific Software Assurance benefits are offered will take precedence in the case of any conflict with the information provided here. For eligibility criteria and current benefit program rules, see the Microsoft Product List.

The contents of this guide are subject to change. Please go to <http://www.microsoft.com/sqlserver/2008/en/us/licensing.aspx> for the most current version of this guide.

Introduction

Overview

This guide is for Microsoft customers who need to understand how Microsoft® SQL Server® is licensed and sold. In addition to information about SQL Server releases and sales channels, you will find step-by-step instructions and examples for determining **when a server or client needs to be licensed and how to calculate the required licenses**. Among the scenarios covered are:

- Running SQL Server in physical and/or virtual operating system environments
- High availability/failover
- Server farms
- Multiplexing
- Multi-instancing
- More...

Appropriate Use

This guide is intended to be used to help Microsoft customers gain a basic understanding of the licensing models and rules for SQL Server and to help you determine the correct license requirements for a given scenario. Most scenarios are covered here. If you cannot find the information you need for a specific scenario in this guide, contact your Microsoft reseller or account manager.

This guide does not supersede or replace any of the legal documentation covering SQL Server use rights. Specific product license terms are defined in the product's Software License Terms, the Microsoft Volume Licensing agreement under which it was acquired, and/or the Microsoft Volume Licensing Product Use Rights (PUR). It is not for external distribution, nor is it a legal use rights document. Program specifications and business rules are subject to change.

This *SQL Server Licensing Guide* will be updated as needed. For the latest version, please visit <http://www.microsoft.com/sqlserver/2008/en/us/licensing.aspx>.

Contents

Chapter 1: What is Sold: SQL Server Releases	1
Chapter 2: Who Sells It: Sales Channels for SQL Server	6
Chapter 3: How Licenses are Counted: Licensing Models for SQL Server	11
Chapter 4: How to Count Licenses in Advanced Scenarios Part 1: Virtualization and License Mobility	21
Chapter 5: How to Count Licenses in Advanced Scenarios Part 2: High Availability, Multiplexing, and Components	35
Chapter 6: Other Microsoft Products that Run on SQL Server	48
Chapter 7: Upgrades, Downgrades, and Step-ups	54
Chapter 8: Software for Evaluation, Development, Training, and Demos	57
Chapter 9: Media Fulfillment	59
Chapter 10: Pricing and Additional Resources	60

Chapter 1: What is Sold: SQL Server Releases

IN THIS CHAPTER

SQL Server Versions and Editions	1
Hardware Platforms Supported	3
Multi-Language Support	3
Restrictions on Deployment	4

KEY TERMS INTRODUCED

Edition: The “level” of the product (e.g. “Enterprise” or “Standard”)

Platform: The operating system environment on which applications run (e.g. x86 [32-bit] or x64 [64-bit])

Version: The release of the product (e.g. SQL Server 2005 or SQL Server 2008)

SQL Server Versions and Editions

The table below provides a summary of the versions and editions for Microsoft® SQL Server® 2008, SQL Server 2005, and SQL Server 2000.

Note: The information and examples used in this guide generally apply to SQL Server 2008. Licensing rules for prior versions are the same except where noted.

TABLE 1.1: SQL SERVER VERSIONS AND EDITIONS

Editions	Platforms Supported			Target Scenarios for SQL Server 2008 Editions
	x86 (32-bit)	x64 (64-bit)	IA64 (64-bit Itanium)	
SQL Server 2008 Enterprise	•	•	•	<ul style="list-style-type: none"> Enterprise workloads that need redundancy and built-in Business Intelligence Enterprise virtualization Server farm with license mobility
SQL Server 2005 Enterprise	•	•	•	
SQL Server 2000 ¹ Enterprise	•	•	•	
SQL Server 2008 Standard	•	•	•	<ul style="list-style-type: none"> Shared data scenarios in departments and small to large businesses Departmental Essential Business Server customers
SQL Server 2005 Standard	•	•	•	
SQL Server 2000 Standard	•	•	•	
SQL Server 2008 Developer	•	•	•	<ul style="list-style-type: none"> Full featured edition for development and testing only
SQL Server 2005 Developer	•	•	•	
SQL Server 2000 Developer	•	•	•	
SQL Server 2008 Workgroup	•	•	•	<ul style="list-style-type: none"> Remote/branch offices that need local instances of company data Small scale
SQL Server 2005 Workgroup	•	•	•	

Editions	Platforms Supported			Target Scenarios for SQL Server 2008 Editions
	x86 (32-bit)	x64 (64-bit)	IA64 (64-bit Itanium)	
SQL Server 2008 Compact 3.5	•			<ul style="list-style-type: none"> • Developing desktop and mobile applications • Client embedded
SQL Server 2005 Compact	•			
SQL Server 2005 CE	•			
SQL Server 2008 Web	•	•		<ul style="list-style-type: none"> • Web application hosting
SQL Server 2008 Express	•	•		<ul style="list-style-type: none"> • Entry-level • Learning • Core database engine only • ISV distribution • Free
SQL Server 2008 Express with Tools	•	•		<ul style="list-style-type: none"> • Same as Express, but with SQL Server Management Studio Basic
SQL Server 2008 Express with Advanced Services	•	•		<ul style="list-style-type: none"> • Same as Express with Tools, but with SQL Server Reporting Services and Text-based Search
SQL Server 2008 Standard Edition for Small Business²	•	•	•	<ul style="list-style-type: none"> • Small businesses with fewer than 75 users
SQL Server 2008 Enterprise Evaluation	•	•	•	<ul style="list-style-type: none"> • 180-day trial • Free
SQL Server 2000 Personal	•			

¹SQL Server 2000 is no longer available for purchase.

²Any number of instances of the server software may be run in one physical or virtual operating system environment (OSE) on the licensed server at a time. The OSE in which instances of the server software run must be joined to a domain that has Microsoft Active Directory[®] configured to have a single server in the domain that contains all the flexible single master operations (FSMO) roles and is the root of the Active Directory forest, no trust relationships with any other domains, no child domains, and no more than 75 total users/devices.

 For more information, visit <http://www.microsoft.com/sqlserver/2008/en/us/editions.aspx>.

Hardware Platforms Supported

SQL Server products may be used on any hardware platform on which the software runs.

DIAGRAM 1.1: SQL SERVER LICENSES ARE PLATFORM INDEPENDENT

SQL Server licenses and installation media allow you to install any platform of the licensed edition.

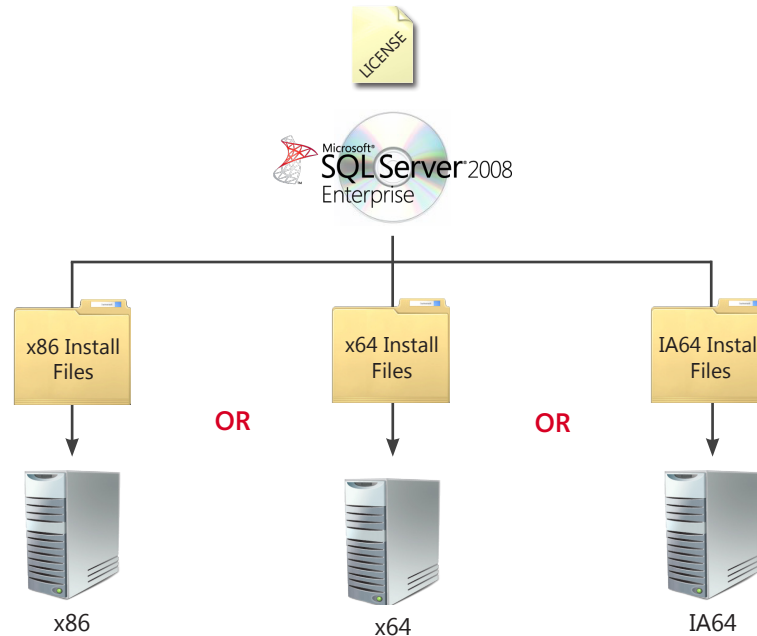

Multi-Language Support

SQL Server 2008 is available in the following languages:

- English
- Chinese Simplified
- Chinese Traditional
- French
- German
- Italian
- Japanese
- Korean
- Portuguese (Brazilian)
- Russian
- Spanish

DIAGRAM 1.2: SQL SERVER 'ALL LANGUAGE' SKUs

SQL Server 'All Language' SKUs through Microsoft Volume Licensing permit you choose which language you deploy:

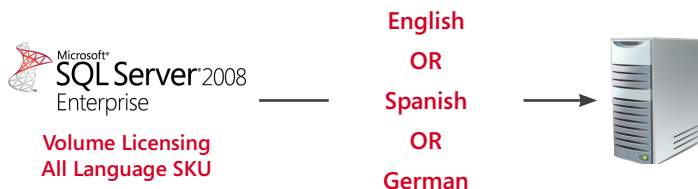

RULE 1.1: CHANGING LANGUAGES

- If you are licensed for a specific language through Volume Licensing, you may change to a different language provided that the license price for the new language is less than or equal to the license price for the current language.

Restrictions on Deployment

Depending upon the edition of SQL Server, certain limits may apply to how the product may be deployed. Below is an overview of the primary limits.

Note: This is a summary only. See Chapter 2 for more information about where to find the applicable terms and conditions. Additionally, limits on memory are affected by the specific configuration.



TABLE 1.2: PROCESSOR, MEMORY, AND DATABASE SIZE LIMITS BY SQL SERVER 2008 EDITION

	Enterprise	Standard	Workgroup	Web	Developer	Express	Compact
# of Processors ¹	OS Maximum	4	2	4 CPU	OS Maximum	1	OS Maximum
Memory	OS Maximum	OS Maximum	4 GB (64-bit)/ OS Maximum (32-bit)	OS Maximum	OS Maximum	1 GB	~1.5 MB
DB Size	Unlimited	Unlimited	Unlimited	Unlimited	Unlimited	4 GB	4 GB

¹The following is considered a single processor for purposes of this table:

- A single-core, hyper-threaded processor with two logical CPUs per socket
- A dual-core processor with two logical CPUs
- A quad-core processor with four logical CPUs

 **TABLE 1.3: SOME ADDITIONAL LIMITATIONS FOR SQL SERVER DEVELOPER AND WEB EDITIONS**

		Permitted 	Not Permitted 
Developer		Development, testing, and internal demos	Production environments
Web	Internal-facing	Not applicable	<ul style="list-style-type: none"> • Web apps, sites, and services • Line of Business apps (e.g. CRM, HR)
	External-facing	Web apps, sites, and services	Line of Business apps

Chapter 2: Who Sells It: Sales Channels for SQL Server

IN THIS CHAPTER

Overview of Sales Channels for SQL Server	6
Volume Licensing Programs for End Customer Organizations	7
Volume Licensing SKU Types	7
Volume Licensing Program Types	9
Perpetual and Temporary Licenses	9
Overview of Volume Licensing Programs for End Customer Organizations	10

KEY TERMS INTRODUCED

- Comprehensive licensing:** Programs through which customers pay for license coverage on an annual basis based on a counting mechanism
- Full Packaged Product (FPP):** Boxed product sold through the retail channel
- License (L):** SKU type that provides customer with the right to use the product
- License & Software Assurance Pack (L/SA):** SKU type that includes both the License and Software Assurance for the product
- PUR:** Product Use Rights are the legal terms and conditions for products licensed through the Volume Licensing channel
- Software Assurance (SA):** Program offering that provides automatic access to new technology and productivity benefits, support, tools, and training to help deploy and use software efficiently
- Software License Terms:** Legal terms governing use of single software titles acquired by an individual through the retail or OEM channels.
- Stock Keeping Unit (SKU):** Part number used to order a license
- Transactional licensing:** Programs through which customers acquire licenses and/or Software Assurance on an as-need basis
- Volume Licensing:** Purchasing programs that provide discounts to organizations acquiring multiple licenses

Overview of Sales Channels for SQL Server

Microsoft sells Microsoft® SQL Server® licenses through channels designed to meet the unique needs of customers. The channel the licenses are sold through determines which document(s) details the use rights for the licensed products.

TABLE 3.1: OVERVIEW OF SQL SERVER SALES CHANNELS

Who Sells it to End Customers	Program	Who Can Participate	Product Use Rights Detailed In
Online retailers	Full Packaged Product (FPP)	End customers/consumers needing a single copy of SQL Server	Retail version of Software License Terms ¹
Microsoft (direct) - Enterprise Software Advisors (ESAs) Resellers (indirect) - Large Account Resellers (LARs), Authorized Education Resellers (AERs)	Volume Licensing for End Customer Organizations	Qualifying customer organizations ²	Microsoft Volume Licensing Product Use Rights (PUR) ³
Original Equipment Manufacturers (OEM)	OEM Royalty, OEM Embedded	OEMs selling SQL Server with hardware	OEM version of Software License Terms
Independent Software Vendors (ISVs)	ISV Royalty Licensing Program (ISVR)	ISVs integrating SQL Server into software business applications sold to end customers	ISV Royalty Agreement ³
Application Service Providers (ASPs)	Services Provider License Agreement (SPLA)	Service providers licensing SQL Server on a monthly basis to provide services and hosted applications to their end customers	Service Provider User Rights (SPUR) ³

¹Channel partner agreement may override the Software License Terms in some cases

²Qualifications vary by program, organization type, and purchase quantity

³Important product use rights information is also included the Microsoft Volume Licensing Product List and the customer's licensing agreement

Volume Licensing Programs for End Customer Organizations

Microsoft offers Volume Licensing programs designed to meet the purchasing and software asset management needs for end customer organizations of various sizes, with various needs, and across various industries.

Volume Licensing SKU Types

SKUs (Stock Keeping Units) are the part numbers on the Microsoft Volume Licensing price lists that are used to order a particular item. There are four licensing SKU types available to customers for SQL Server products through Microsoft Volume Licensing programs.

 **DIAGRAM 2.1: VOLUME LICENSING SKU TYPES**

License (L)

Part Number	Item Name	Product Type
810-07608	SQL Svr Enterprise Edtn 2008 All Lng MVL	Standard

- Use to license a specific version and edition of the software
- Also referred to as “Standard” SKU

Software Assurance (SA)

Part Number	Item Name	Product Type
810-04760	SQL Svr Enterprise Edtn All Lng SA MVL	Software Assurance

- Use only to renew/extend SA coverage or to enroll qualifying OEM or FPP licenses in SA within 90 day of license purchase
- In addition to other benefits, permits you to upgrade to new releases of the software during the SA term

License and Software Assurance Pack (L/SA)

Part Number	Item Name	Product Type
810-04764	SQL Svr Enterprise Edtn All Lng Lic/SA Pack MVL	License/Software Assurance Pack

Use to acquire both a license and SA coverage for the license

SA Step-Up

Part Number	Item Name	Product Type
810-04857	SQL Svr Enterprise Edtn All Lng SA Step Up MVL SQL Svr Std	SA Step Up

Use to migrate customers with SA from a lower edition to a higher edition of the software

Software Assurance Overview

The table below shows the Software Assurance benefits applicable to SQL Server that are available to commercial and government Volume Licensing customers.

TABLE 3.2 SOFTWARE ASSURANCE BENEFITS THAT ARE APPLICABLE TO SQL SERVER

	Open License	Select License and Select Plus	Open Value Non-company-wide	Open Value Company-wide and Subscription	Select License with SAM, Select Plus with SAM, Enterprise Agreement, Enterprise Subscription Agreement
New Version Rights	●	●	●	●	●
Spread Payments		●	●	●	●
E-Learning	●	●	●	●	●
24x7 Problem Resolution Support	●	●	●	●	●
"Cold" Backups for Disaster Recovery	●	●	●	●	●
TechNet Subscription		●	●	●	●
Extended Hotfix Support	●	●	●	●	●

Options At the End of the SA Term

When you want SA coverage on a new license, the L/SA SKU is used. If you choose to extend the SA coverage when it expires, you purchase just the SA SKU. If you do not extend your SA coverage, you can continue to use the most current version of the software (or a downgrade version), but will not be entitled to further upgrades. To upgrade in the future, you would need to acquire a new License (L) or L/SA.

Note: The term of the SA coverage depends upon the licensing agreement under which it was acquired and the timing of the purchase.



EXAMPLE 2.1: CUSTOMER WITH L/SA FOR SQL SERVER 2005 STANDARD

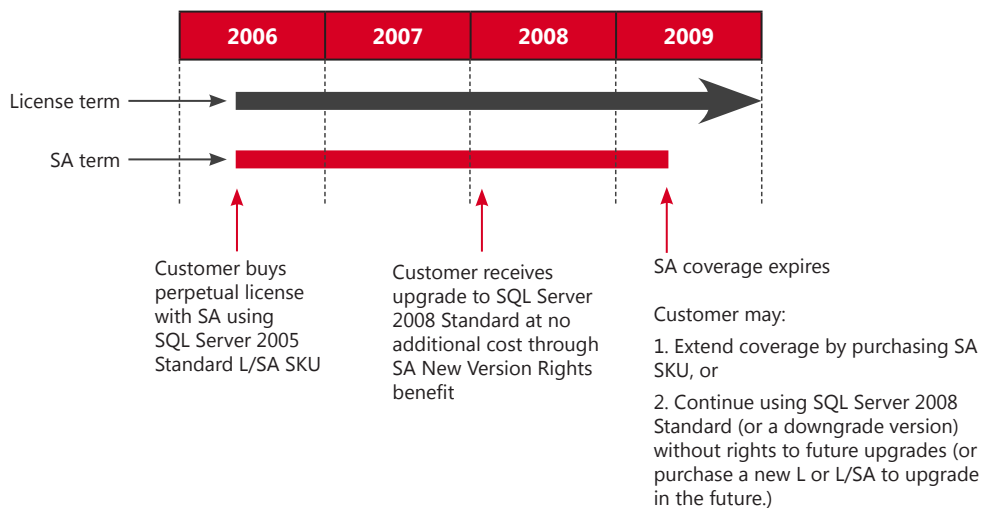

Enrolling OEM or FPP Licenses in Software Assurance

If you purchase SQL Server through the retail FPP or OEM channels, you have 90 days to enroll the license in SA. To do so, you purchase the SA SKU through a Volume Licensing program.

Volume Licensing Program Types

Microsoft Volume Licensing programs can be classified into two general categories: Transactional and Comprehensive (also referred to as “subscription” or “annuity”).

TABLE 3.3: TRANSACTIONAL VS. COMPREHENSIVE VOLUME LICENSING PROGRAMS

Transactional	Comprehensive
You acquire licenses and/or Software Assurance as needed	Depending on the Volume Licensing program, you make an annual payment based on counting desktops, installed copies, or Full-time Equivalent Employees (FTE)

Perpetual and Temporary Licenses

Depending upon the Volume Licensing program, licenses are offered as perpetual or temporary (non-perpetual). Perpetual licenses never expire and permit the owner to use the licensed software for an unlimited period of time. Non-perpetual licenses permit the user to use the licensed software for a specified period of time. Temporary licenses are only available through certain comprehensive licensing programs.

DIAGRAM 2.2: LICENSE TERM FOR PERPETUAL VS. NON-PERPETUAL LICENSES

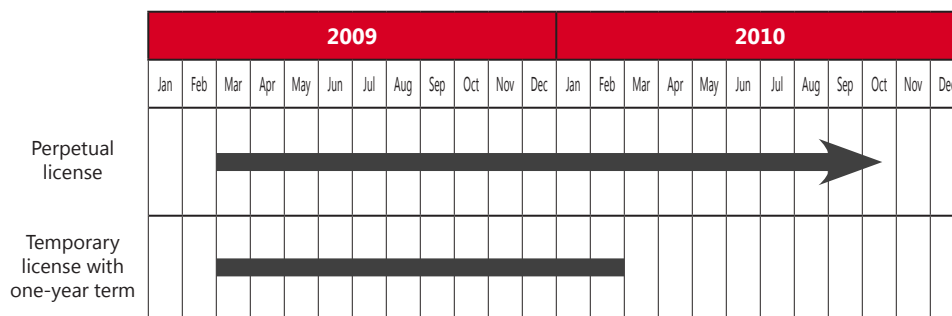

Overview of Volume Licensing Programs for End Customer Organizations

The following table provides an overview of the Volume Licensing programs available to end customer organizations.

TABLE 3.4: MICROSOFT VOLUME LICENSING PROGRAMS FOR END CUSTOMERS

(T) = Temporary licenses offered

Customer Organization Size	Customer Industry	Program Type	
		Transactional	Comprehensive
Small to Midsize	Commercial	Open License	<ul style="list-style-type: none"> Open Value Open Value Subscription (T)
	Academic	Open License for Academic	
	Government	Open License for Government	Open Value for Government
	Nonprofit	Open License for Charities	
Midsize to Large	Commercial	<ul style="list-style-type: none"> Select License Select Plus 	<ul style="list-style-type: none"> Enterprise Agreement Enterprise Subscription Agreement (T)
	Academic	<ul style="list-style-type: none"> Select License for Academic Select Plus for Academic 	Campus and School Agreement (T)
	Government	<ul style="list-style-type: none"> Enterprise Agreement for Government Select License for Government Select Plus for Government 	Enterprise Subscription Agreement for Government (T)

Note: Program availability may vary by geographical region.

i For more information, go to <http://www.microsoft.com/licensing>.

Chapter 3: How Licenses are Counted: Licensing Models for SQL Server

IN THIS CHAPTER

Overview	11
Anatomy of a Server	11
Server/CAL Licensing	12
Multi-core Processors	16
Choosing the Best Model	16
Assessing Your Needs	20

KEY TERMS INTRODUCED

Client Access License (CAL): License granting a device or user the right to access or use the services or functionality of the server software

Core: Processing execution unit on a processor

Device CAL: Licenses a device accessing or using the services or functionality of the server software

Multi-core processor: A processor chip that consists of multiple processing execution units or “cores”

Per Processor: Licensing model based on the number of processors; permits an unlimited number of users or devices to access or use the services or functionality of the server software

Processor: A complete computation engine that is fabricated on a single chip and performs the “work” of the computer. (Also referred to as a “microprocessor” or “CPU” (central processing unit))

Physical operating system environment (POSE): Computing environment on the physical hardware in which the operating system and applications run

Server/CAL licensing: Licensing model where licenses are acquired for both the server on which the server software is run and the users and/or devices accessing or using the services or functionality of the server software

Server license: Licenses the server on which SQL Server software or any of its components is running

User CAL: Licenses a user accessing or using the services or functionality of the server software

Virtual machine (VM): A software implementation of a computer that executes programs like a real computer

Virtual operating system environment (VOSE): Virtual environment in which the operating system is emulated and applications (such as SQL Server) run

Virtualization: Running software in a virtual operating environment

Overview

When licensing Microsoft® SQL Server® through your Microsoft Volume Licensing agreement, you may choose between two main licensing models: Server/Client Access License (CAL) and Per Processor.

This chapter includes guidance about the different models and general guidelines as to which is recommended for certain scenarios.

Anatomy of a Server

The diagram below shows how the key components of a physical server (also referred to as the “physical machine”) and a virtual machine (VM) on which SQL Server is running are represented in the various diagrams and examples that follow.

DIAGRAM 3.1: PHYSICAL SERVER AND VIRTUAL MACHINE RUNNING SQL SERVER

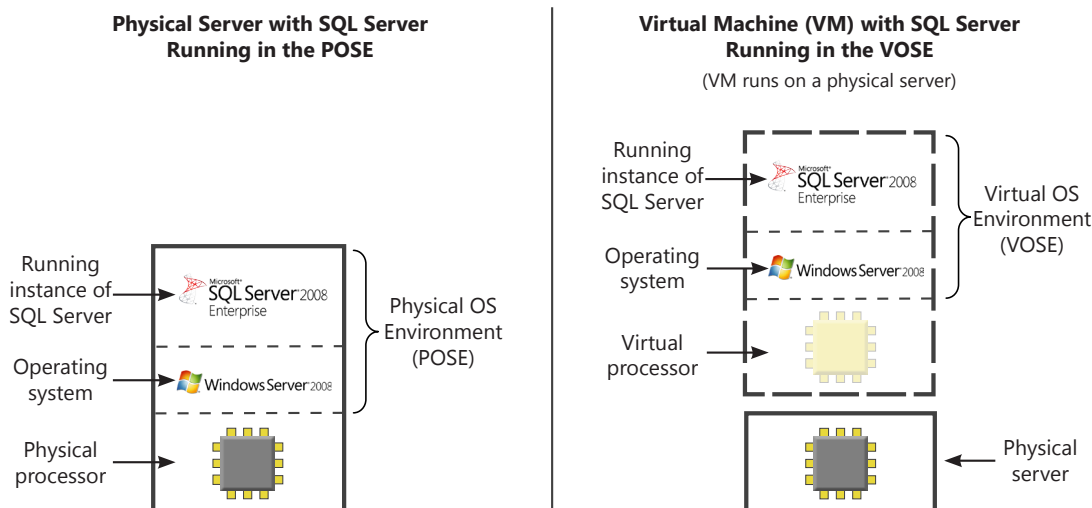

Server/CAL Licensing

When licensing SQL Server under the Server/CAL model, you purchase a Server license for the server and Client Access Licenses (CALs) for each device (Device CALs) and/or users (User CALs) accessing or using the services or functionality of SQL Server. A CAL is not software; it is a legal document granting access. Note: Separate partitions or blades are considered to be separate servers for licensing purposes.

DIAGRAM 3.2: SERVER LICENSE AND CALS

Server license

Licenses the server on which SQL Server software or any of its components is running

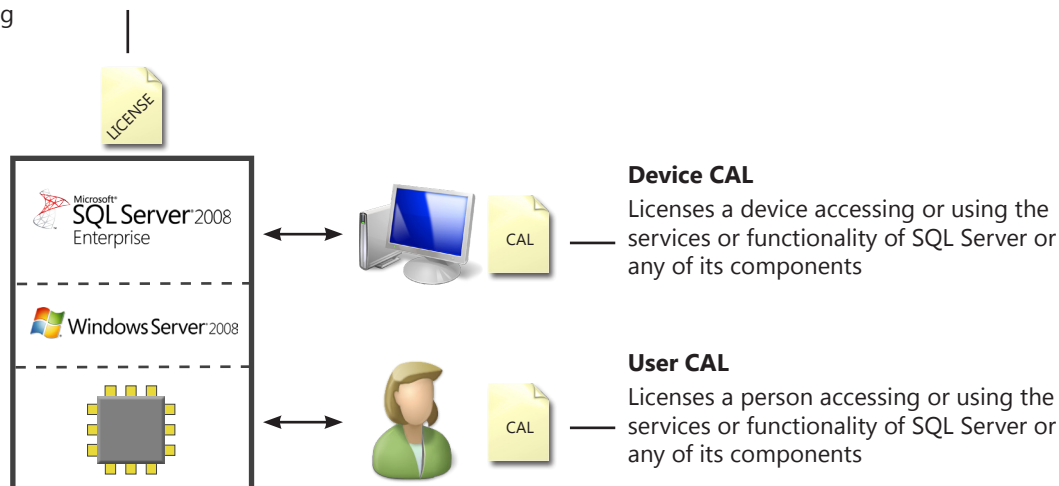

! RULES 3.1 COUNTING CALS

- A given user or device only needs one SQL Server CAL to access any number of SQL Server instances in your organization.
- SQL Server Workgroup and SQL Server Standard for Small Business editions have their own CALs that can only be used with those respective editions.
- SQL Server CALs can be used with any edition of SQL Server, including SQL Server Workgroup and SQL Server Standard for Small Business editions.
- Windows Small Business Server (SBS) 2008 CAL Suite for Premium Users or Devices may be used instead of SQL Server 2008 CALs to access instances of the server software within an SBS domain.
- Servers running SQL Server instances that connect to other servers running SQL Server instances require Server licenses, but do not require SQL Server CALs
- Manual data-transfer to/from SQL Server does not require CALs. For instance, if User A sends data to User B, who in turn enters data into SQL Server, User A does not need a CAL.
- SQL Server CALs can also be used against any SQL Server regardless of the platform (32 bit, 64 bit, and IA64).
- If enrolled in Software Assurance (SA) or Enterprise Agreement (EA), you can switch from Device CALs to User CALs, or from User CALs to Device CALs, upon renewal of SA or EA.
- Users or Devices accessing SQL Server components (e.g. Reporting Services) require CALs
- Use of hardware and/or software that reduces the number of devices or users that directly access or use the software (multiplexing/pooling) does not reduce the number of CALs required. *See Multiplexing section in Chapter 5 for more information.*
- If a user or device is accessing an application that connects to SQL Server (directly or indirectly), a CAL is required—even the application and SQL Server are running on different physical hardware systems. *See Multiplexing section in Chapter 5 for more information.*

DIAGRAM 3.3: COUNTING SERVER/CAL LICENSES FOR A SINGLE PHYSICAL SERVER

Under the Server/CAL model, you must purchase and assign one SQL Server license to each server:



Next, CALs are required for either the devices or the users that connect to or use the SQL Server data. If CALs are purchased for a device, any number of users can use that device to connect to and use the SQL Server data:

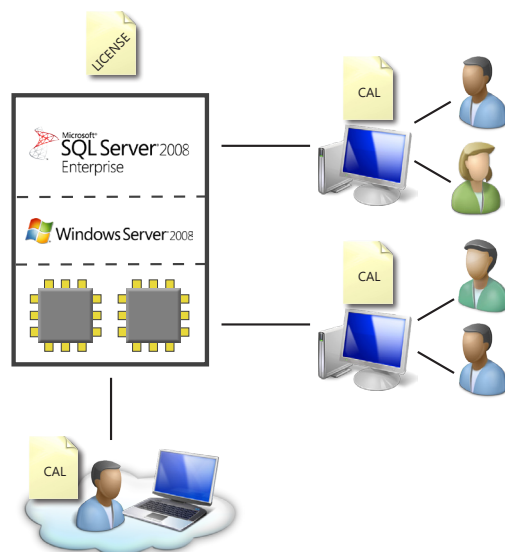

DIAGRAM 3.4: YOU MAY USE A COMBINATION OF USER CALS AND DEVICE CALS

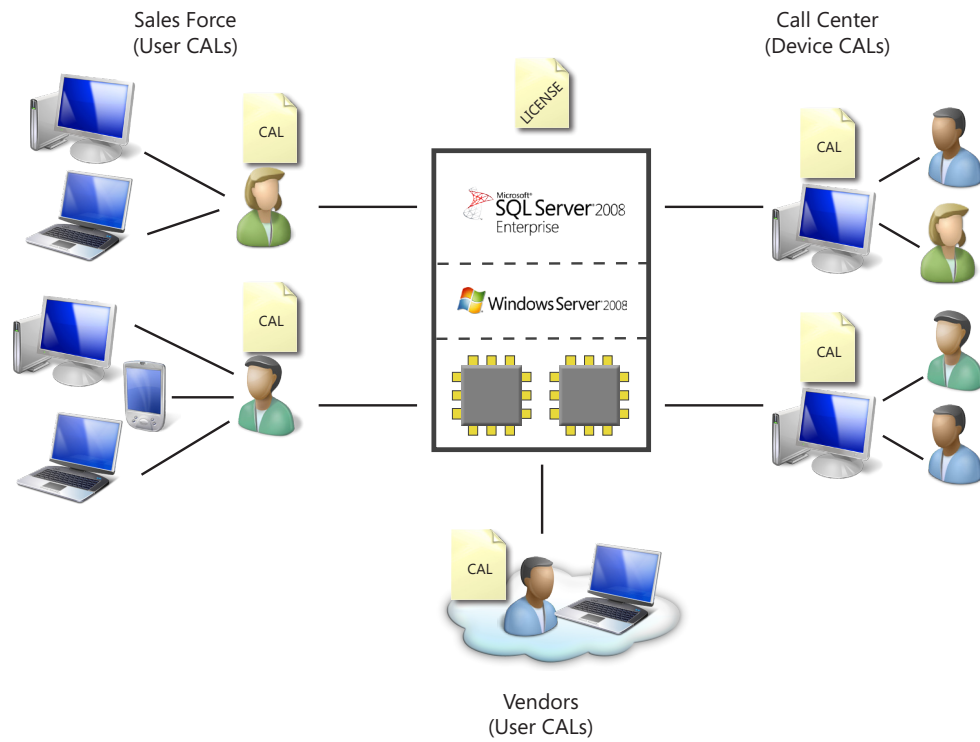
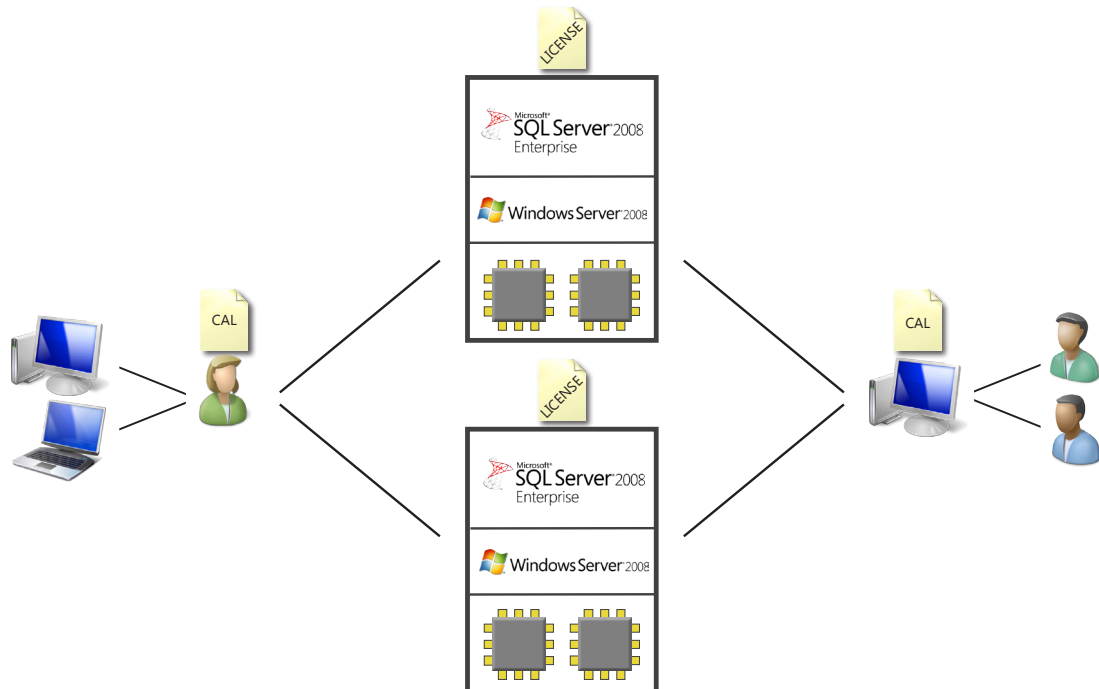

DIAGRAM 3.5: SQL SERVER CALs PERMIT ACCESS TO ANY LICENSED SERVER

SQL Server CALs permit access to any licensed server within your organization. Additional CALs are not required for additional servers:



Per Processor Licensing

Microsoft offers a Per Processor licensing model to help alleviate complexity. When licensing SQL Server under the Per Processor model, you do not need to purchase additional CALs; it includes access for an unlimited number of users or devices to connect from either inside or outside the firewall. Processor licenses for SQL Server 2008 are available for Enterprise, Standard, Web, and Workgroup editions.

⚠️ RULES 3.2: PER PROCESSOR LICENSING

- A Processor license is required for each processor installed on each operating system environment (OSE) running SQL Server or any of its components (for example, Analysis Services).
- For SQL Server running in physical operating system environments (POSEs), you must license each physical processor.

📌 For more information about how to calculate the required number of Processor licenses for SQL Server running on a virtual machine (VM), refer to Chapter 4.

🔍 EXAMPLE 3.1: COUNTING PROCESSOR LICENSES FOR TWO PHYSICAL SERVERS

Server 1 below has one processor and Server 2 has two processors, therefore three Processor licenses are required:

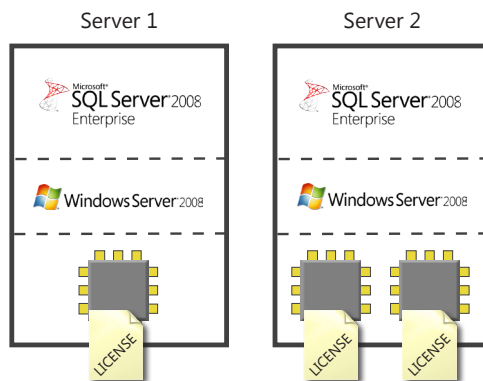

With those three Processor licenses, any number of devices and users may connect to and use the SQL Server data on the servers. CALs are not required:

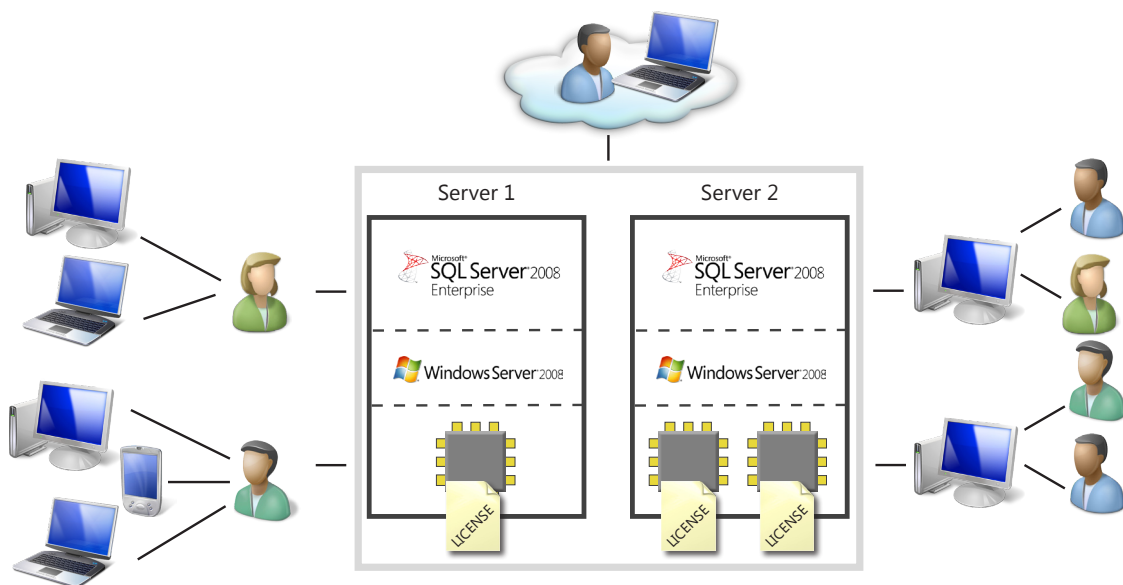

Multi-core Processors

Multi-core processors, which consist of multiple processing execution units or “cores” on one chip, are seen as a promising way to boost computing power. For Processor licenses, Microsoft charges by the processor, not by the core.

 **DIAGRAM 3.6: MULTI-CORE PROCESSORS**

Each of these physical processors would require a single Processor license for SQL Server:

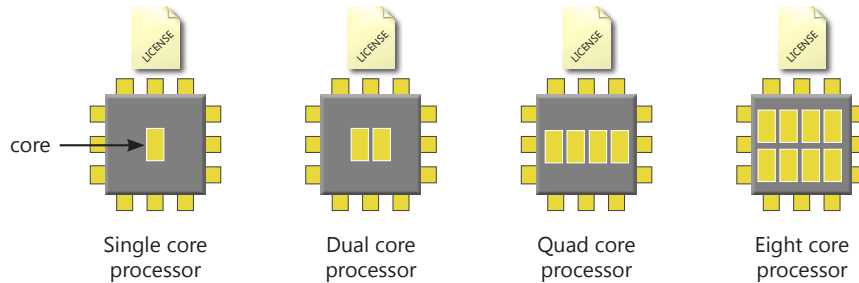

Choosing the Best Model

Use this information as a guide to finding the most appropriate licensing model for a given scenario.

? DECISION TREE 3.1: GENERAL GUIDANCE ON CHOOSING A LICENSING MODEL FOR A SINGLE PROJECT

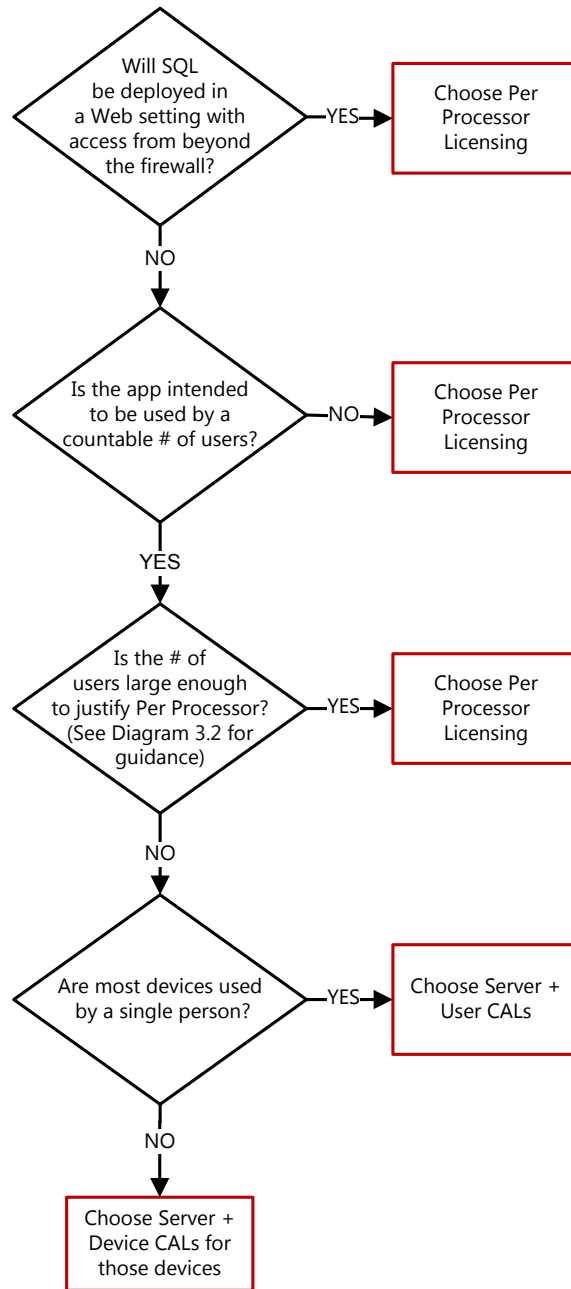

? DECISION TREE 3.2: GENERAL GUIDANCE ON CHOOSING A LICENSING MODEL FOR AN ORGANIZATION

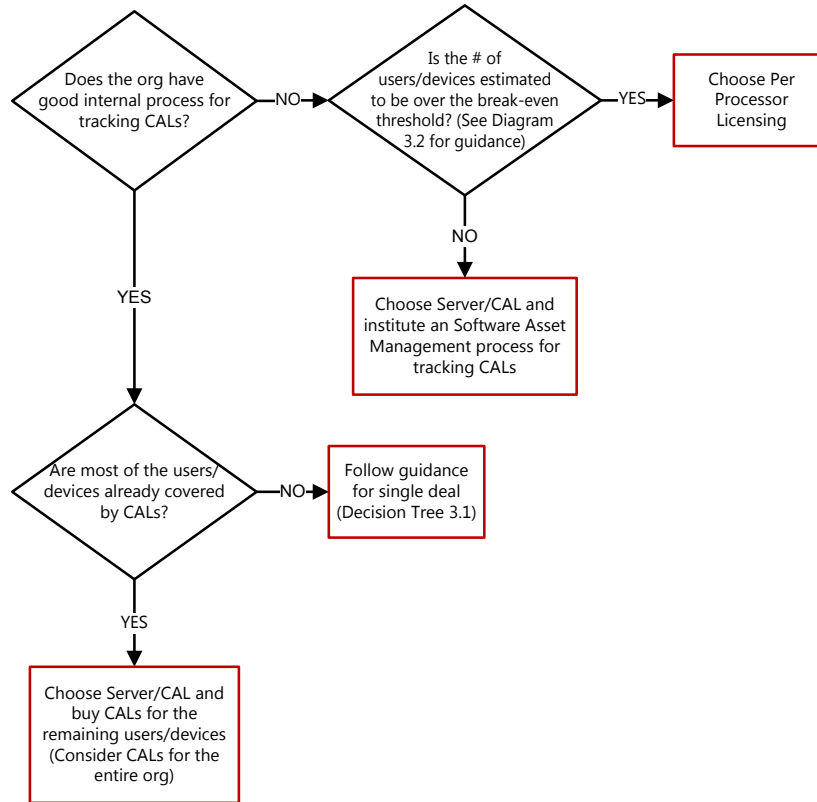
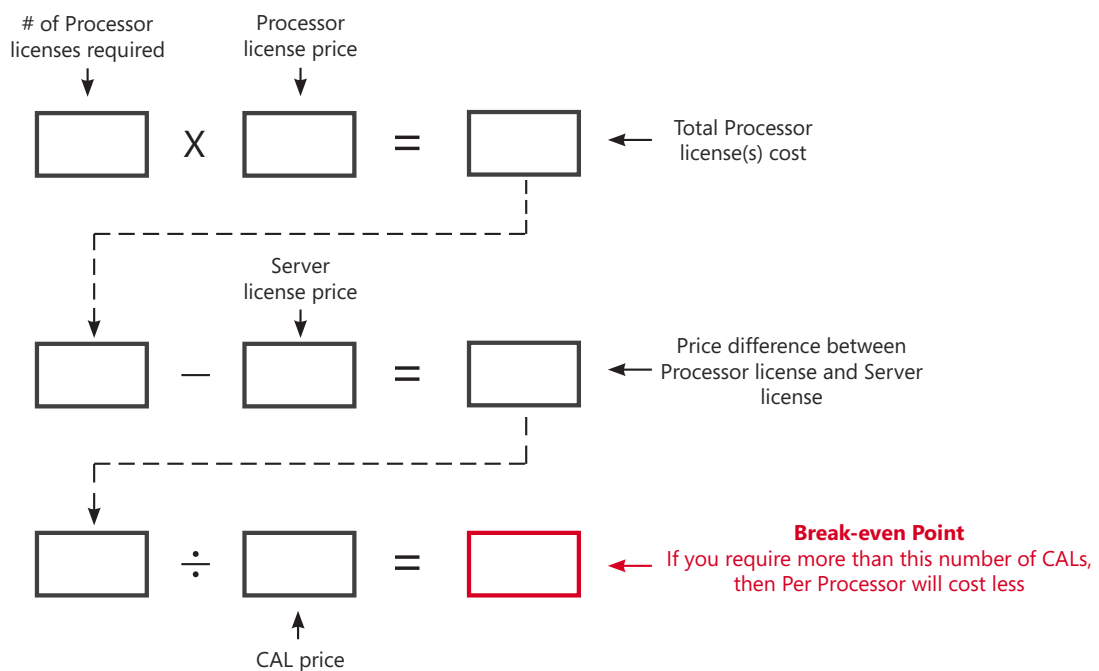

DIAGRAM 3.2: HOW TO CALCULATE BREAK-EVEN POINT FOR PER PROCESSOR LICENSING



EXAMPLE 3.2: BREAK-EVEN POINT FOR PER PROCESSOR LICENSING: SINGLE SERVER

In this example, we'll calculate the break-even point for a single SQL Server 2008 Enterprise license with two processors based on U.S. Select Plus Level A Estimated Retail Pricing as of December 2008.

Note: The prices used here are for example only. The actual end customer pricing varies by the channel through which the SQL Server licenses are purchased, and final pricing is set by the reseller.

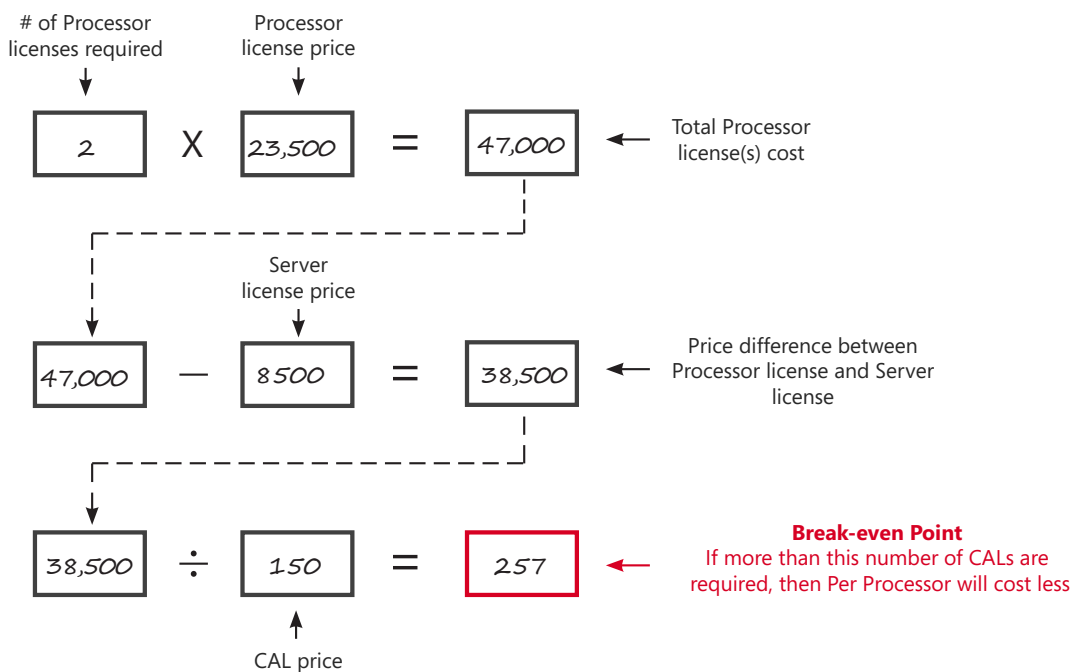
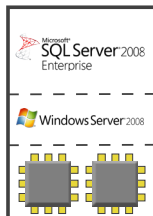

In this case, if the organization requires more than 257 CALs, then it would cost less to acquire a Processor license.

EXAMPLE 3.3: BREAK-EVEN POINT FOR PER PROCESSOR LICENSING: MULTIPLE SERVERS

In this example, we'll look at which model would be more cost-effective for this deal.

The organization will deploy SQL Server 2008 Standard or SQL Server 2008 Enterprise on each of four servers. They have 800 known users accessing the servers, plus anonymous users accessing the Internet server:

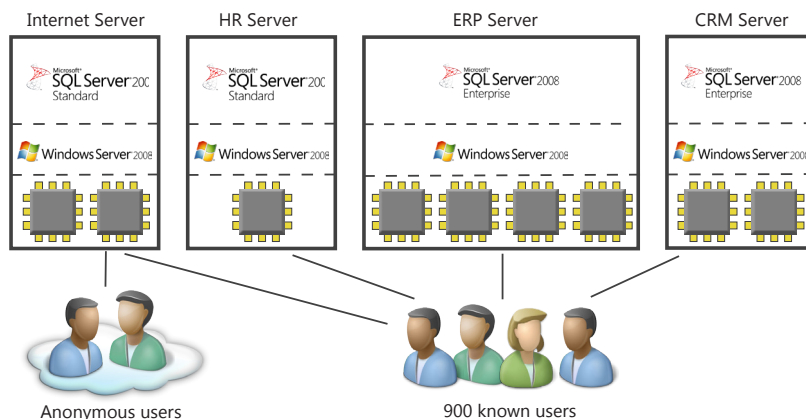

The Internet server must be licensed Per Processor, because it is accessed by an unknown number of people and devices. For the remaining servers, we can calculate the break-even point for each server (the point where Per Processor becomes more cost-effective than Server/CAL) using the formula from Diagram 3.2.

Server	SQL Server Edition	Processors	Processor License Price	Server License Price	CAL Price	Break-even Point (# of Users)
HR	Standard	1	6000	1000	150	33
ERP	Enterprise	4	23,500	8500	150	570
CRM	Enterprise	2	23,500	8500	150	257
Internet	Standard	2	6000	N/A (Must be licensed Per Processor)		

Break-even point: 860 users

Because the break-even point is 860 users—and the organization has 900 users—it would be more cost-effective to license all four servers in Per Processor mode.

Assessing Your Needs

The Microsoft Assessment and Planning Toolkit (MAP) makes it easy for you to assess your current IT infrastructure and determine the right Microsoft technologies for their IT needs.

MAP is a powerful inventory, assessment, and reporting tool that can run securely in small or large IT environments without requiring the installation of agent software on any computers or devices. The data and analysis provided by this Solution Accelerator can significantly simplify the planning process for migrating to Windows Vista®, Microsoft Office 2007, Windows Server 2008, Windows Server 2008 Hyper-V™, Virtual Server 2005 R2, SQL Server 2008, and Microsoft Application Virtualization (formerly SoftGrid).

Among the detailed analysis information MAP provides are:

- Hardware and device compatibility for migration to SQL Server 2008, Windows Server 2008, and Hyper-V server virtualization
- Existing client and server computers where Microsoft SQL Server instances are found
- Virtual machines (VMs) in the computer environment

i For more information, or to download the tool, please visit <http://technet.microsoft.com/en-us/library/bb977556.aspx>.

Chapter 4: How to Count Licenses in Advanced Scenarios

Part 1: Virtualization and License Mobility

IN THIS CHAPTER

Overview	21
Anatomy of a Virtual Machine	21
Multi-core Processors and Hyper-threading	23
Counting Licenses for VMs (Server/CAL Model)	24
Standard and Workgroup Editions	24
Counting Licenses for VMs (Per Processor Model)	25
How to Calculate Processor Licenses for a Single VM	26
How to Calculate Processor Licenses for Multiple VMs	28
How to Calculate Processor Licenses for SQL Server Running on VMs and the POSE	31
Server Application License Mobility: Reassigning Licenses and Moving SQL Server Instances within a Server Farm	31

KEY TERMS INTRODUCED

Cores: Processing execution units on a processor

Hyper-threading technology (HTT): Allows each core to divide the execution of a computer program into two or more concurrently running tasks, called “threads”

Motherboard: The main circuit board inside of the hardware where processor chips, video cards, and other components are connected, receive power, and communicate with one another

Processor: A complete computation unit fabricated on a single chip that performs the “work” of the computer

Socket: Spot on the motherboard where a processor is connected

Threads: Concurrently running tasks executing a computer program

Virtual Machine (VM): An emulated software version of a computer that executes programs like a separate physical computer

Virtual processor: Processor execution unit supporting a VM

Overview

Microsoft® SQL Server® is increasingly being deployed in settings that incorporate virtualization, which enables running instances of SQL Server concurrently in separate virtual operating system environments (VOSEs). Examples of server virtualization technologies include [Microsoft Windows Server® 2008 with Hyper-V](#) and [VMWare](#).

How to determine the number of Server licenses or Processor licenses required for SQL Server running in the physical operating system environment (POSE) is explained in Chapter 3. Here we’ll look at how to calculate the license requirement when SQL Server is running on a virtual machine (VM).

When you are deploying SQL Server on a VM, the license requirements depend upon:

- The licensing model (Server/CAL or Per Processor)
- The edition of SQL Server
- The characteristics of the physical server and VM(s) on which SQL Server will run
- Whether hyper-threading is enabled

Anatomy of a Virtual Machine

Use the diagrams below to familiarize yourself with the characteristics of the VM and physical server that potentially impact the license requirements.

DIAGRAM 4.1: VIRTUAL MACHINE RUNNING SQL SERVER

**Virtual Machine (VM) with SQL Server
Running in the VOSE**

(VM runs on a physical server)

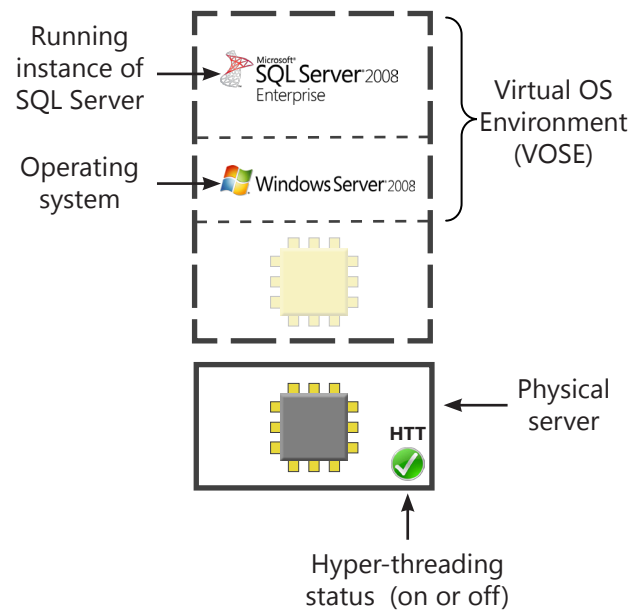
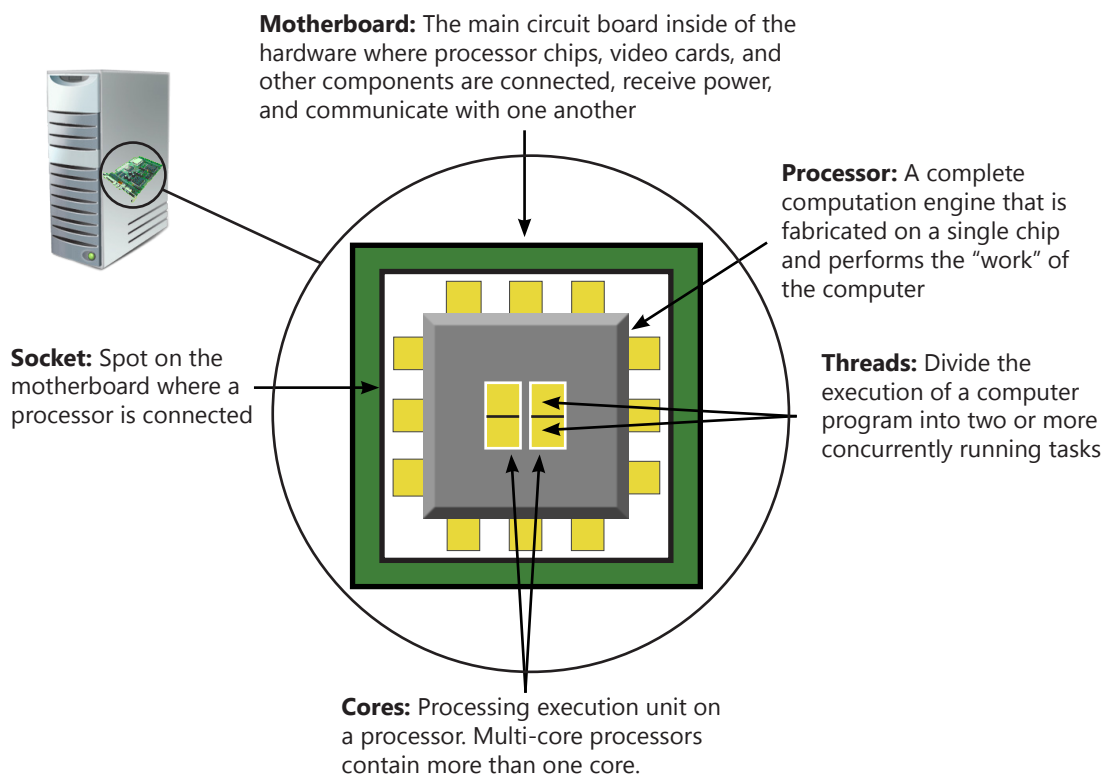

DIAGRAM 4.2: SERVER COMPONENTS



Multi-core Processors and Hyper-threading

When using multi-core processors, each core in the processor essentially acts as a separate processor. Further, Intel's hyper-threading technology (officially called Hyper-Threading Technology or HTT) allows each core to divide the execution of a computer program into two or more concurrently running tasks, called "threads of execution" or just "threads". In these cases, the individual thread essentially acts as a separate processor.

When creating VMs, typically each virtual processor is the equivalent of:

- one core (when hyper-threading is off)
- one thread (when hyper-threading is on)

DIAGRAM 4.3: MAPPING VIRTUAL PROCESSORS TO CORES WHEN HYPER-THREADING IS OFF

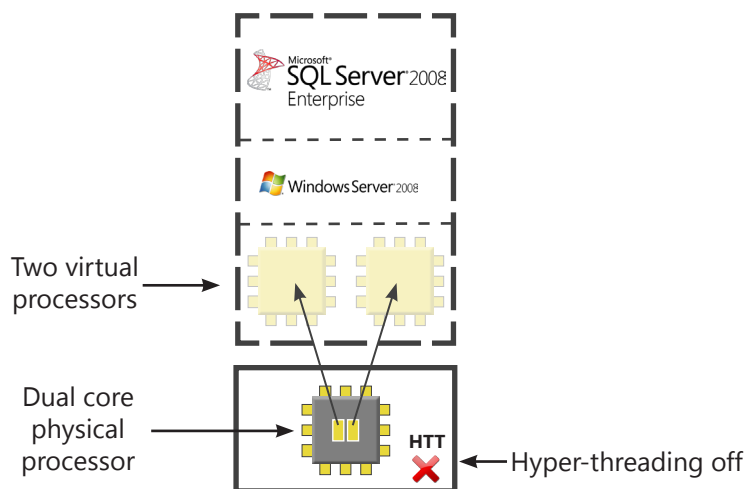
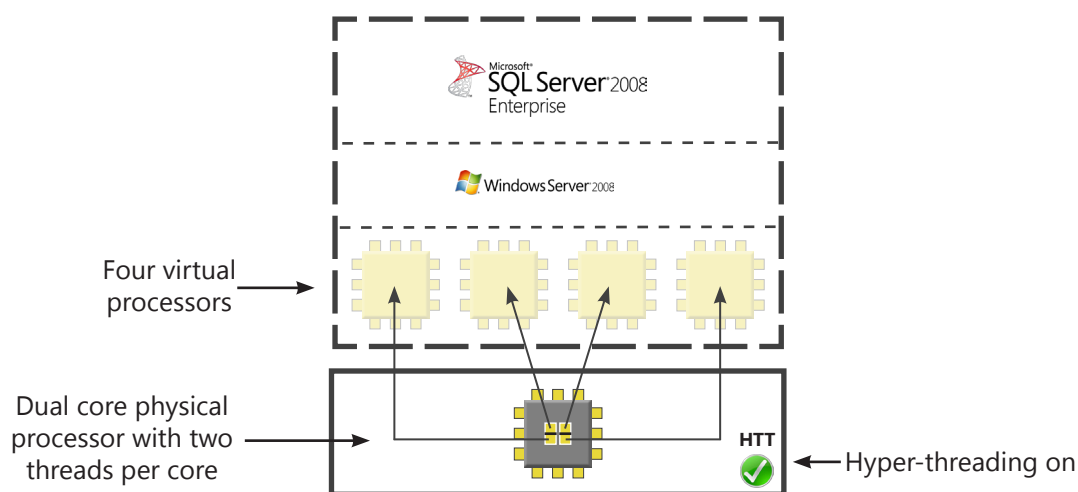

DIAGRAM 4.4: MAPPING VIRTUAL PROCESSORS TO THREADS WHEN HYPER-THREADING IS ON



Counting Licenses for VMs (Server/CAL Model)

RULE 4.1: Count separate blades and partitions on which SQL Server will run as separate servers.

Standard and Workgroup Editions

When licensing SQL Server Standard or Workgroup for virtualization under the Server/Client Access License (CAL) model, each virtual machine (VM) on which SQL Server will run is licensed as if it were a separate physical server. That means...

When licensing SQL Server Standard or Workgroup for virtualization
under the Server/CAL model:

One Server license is required for EACH VM on which SQL Server will run

Enterprise Edition

Each physical server licensed for SQL Server Enterprise under the Server/CAL model is also licensed to run SQL Server Enterprise in as many VMs as the hardware will support. So there is no difference between licensing Enterprise edition for physical and virtual environments.

When licensing SQL Server Enterprise for virtualization
under the Server/CAL model:

One Server license is required for EACH physical server on which SQL Server will run

CAL Requirements

When licensing SQL Server under the Server/CAL model, the CAL requirements are the same for virtual operating system environments (VOSEs) as they are for physical operating system environments (POSEs).

i For details about licensing SQL Server under the Server/CAL model, refer to Chapter 3.

EXAMPLE 4.1: COUNTING LICENSES FOR VMs (SERVER/CAL MODEL)

In this example, an organization is running SQL Server 2008 Standard on two VMs and SQL Server Enterprise on one VM.

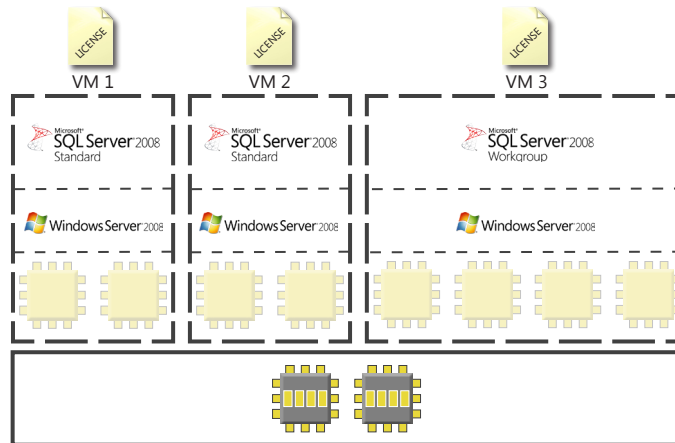

Under the Server/CAL model, each VM gets licensed as if it were a separate physical server, therefore the organization needs:

- Two Server licenses for SQL Server 2008 Standard
- One Server license for SQL Server 2008 Workgroup
- SQL Server CALs as required

Counting Licenses for VMs (Per Processor Model)

Determining the number of Processor licenses required under the Per Processor model depends not only upon the SQL Server edition, but upon how resources in the server are allocated in support of SQL Server.

There are three data points you will want to gather for each VM on which SQL Server will run and the underlying physical machine(s):

- Number of virtual processors supporting the VM
- Number of cores per physical processor (if hyper-threading is off) OR number of threads per physical processor (if hyper-threading is on)
- Number of physical processors

With these data points, you can calculate the required number of Processor licenses for a given SQL Server edition by following a simple formula.

Note: The instructions provided in this guide assume that:

- The number of cores or threads in each processor is the same; and
- If hyper-threading is on, each virtual processor maps to one complete thread.

Most scenarios fit these assumptions. For assistance with determining license requirements in rare scenarios that do not fit these assumptions, gather all of the data about the configuration you can, and then contact your Microsoft reseller or account manager.

DIAGRAM 4.5: COUNTING LICENSES FOR VMs (PER PROCESSOR MODEL)

With data points A – C below, you have the information you need to calculate the number of Processor licenses required for most virtualization scenarios:

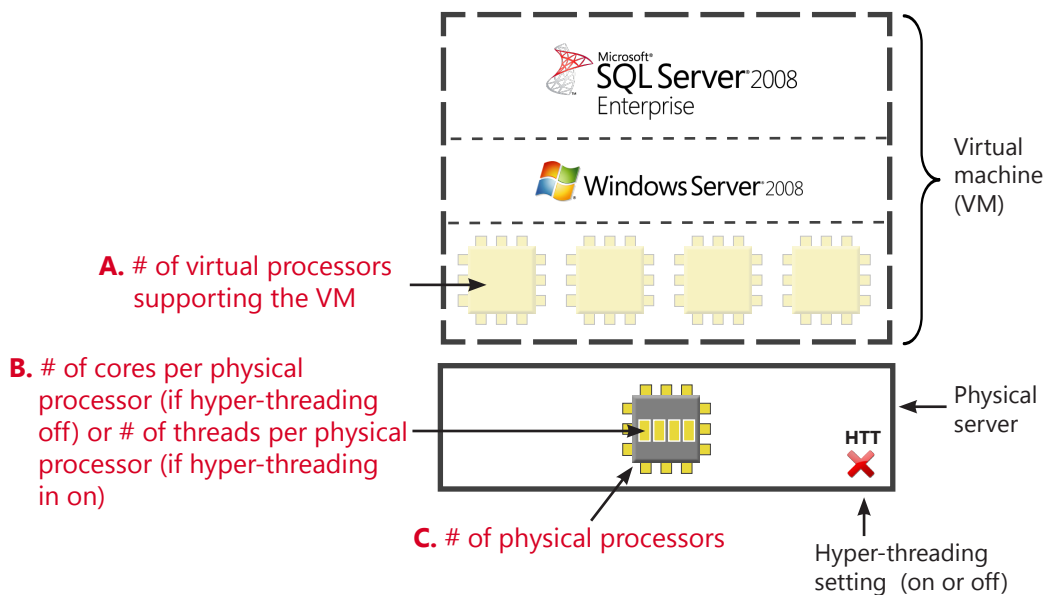

Below you will find instructions on how to use the data points and formulas to calculate the required Processor licenses for:

1. **SQL Server running on a single virtual machine (VM)**
2. **SQL Server running on multiple VMs**
3. **SQL Server running on one or more VMs and the physical OS environment (POSE)**

How to Calculate Processor Licenses for a Single VM

For a single VM, you divide data point A (number of virtual processors supporting the VM) by data point B (# of cores [HTT off] or threads [HTT on] per physical processor) to calculate the number of Processor licenses required for any SQL Server edition(s) that will be licensed. If the result is not a whole number, then you round up to the next whole number.

DIAGRAM 4.6: FORMULA FOR CALCULATING PROCESSOR LICENSES REQUIRED FOR A SINGLE VM

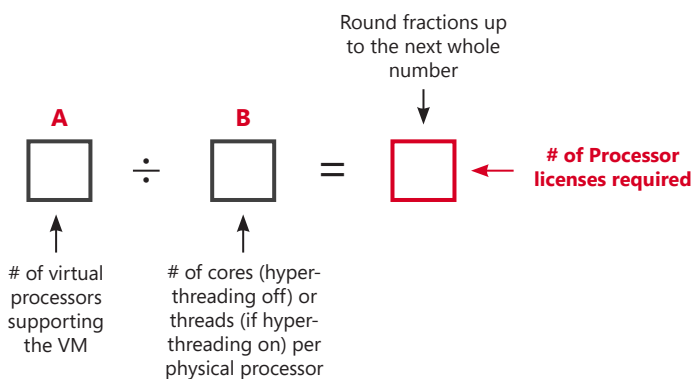

EXAMPLE 4.2: CALCULATING PROCESSOR LICENSES FOR A SINGLE VM WITH HYPER-THREADING OFF

This example server has two quad-core processors supporting one VM running SQL Server. Hyper-threading is off, so each virtual processor is the equivalent of one core.

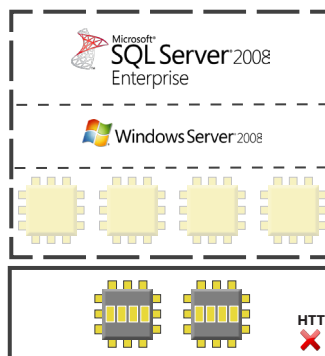

Using the formula above, calculate the number of Processor licenses required:

$$\begin{array}{c}
 \text{A} \\
 \boxed{4}
 \end{array}
 \div
 \begin{array}{c}
 \text{B} \\
 \boxed{4}
 \end{array}
 =
 \begin{array}{c}
 \text{Round fractions up to the next} \\
 \text{whole number} \\
 \downarrow \\
 \boxed{1}
 \end{array}
 \leftarrow \text{\# of Processor licenses required}$$

In this example, just one Processor license is required for any edition.

Note: If both of the physical processors are licensed for SQL Server Enterprise, then the software may be run on as many VMs as the hardware and operating system will support.

EXAMPLE 4.3: CALCULATING PROCESSOR LICENSES FOR A SINGLE VM WITH HYPER-THREADING ON

This example server has two single-core processors supporting one VM running SQL Server. Hyper-threading is on, so each virtual processor is the equivalent of one thread. Each core has two threads, so there are two threads per processor.

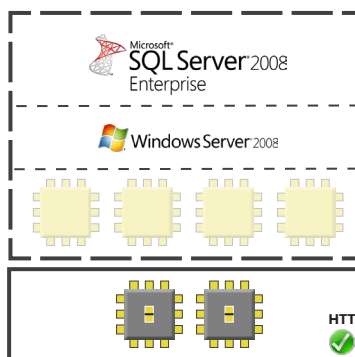

Using data points A and B, calculate the number of Processor licenses required:

$$\begin{array}{c}
 \text{A} \\
 \boxed{4}
 \end{array}
 \div
 \begin{array}{c}
 \text{B} \\
 \boxed{2}
 \end{array}
 =
 \begin{array}{c}
 \text{Round fractions up to the next} \\
 \text{whole number} \\
 \downarrow \\
 \boxed{2} \\
 \uparrow \\
 \text{Number of Processor licenses required}
 \end{array}$$

Note: If both of the physical processors are licensed for SQL Server Enterprise, then the software may be run on as many VMs as the hardware and operating system will support.

How to Calculate Processor Licenses for Multiple VMs

To calculate the Processor licenses required for multiple VMs running SQL Server, calculate the requirements for each VM separately using the same A/B formula, and then add the results for VMs that are running the same edition of SQL Server to get the total number of Processor licenses required for each edition being used.

Note: If all of the physical processors (data point C) are licensed for SQL Server Enterprise, then instances of SQL Server may be run on as many VMs as the hardware and operating system will support. That means you never need more Processor licenses than to total number of physical processors.

DIAGRAM 4.7: CALCULATING PROCESSOR LICENSES FOR MULTIPLE VMs

Calculate the number of Processor licenses required for each individual VM, and then add the results. If different editions of SQL Server will be used, do your calculations in groups by edition to make sure you arrive at the correct number licenses for each edition.



EXAMPLE 4.4: CALCULATING PROCESSOR LICENSES FOR MULTIPLE VMs WITH HYPER-THREADING OFF

This example server has four quad-core processors supporting four VMs running SQL Server. Hyper-threading is off, so each virtual processor is the equivalent of one core.

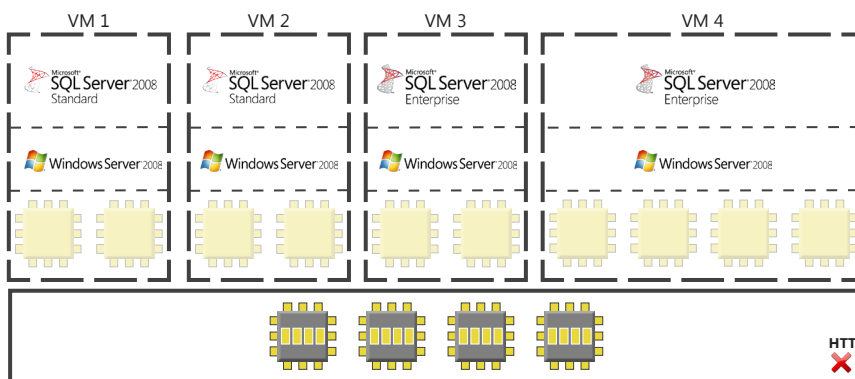

VMs that Will Run SQL Server Standard

Round up to the next whole number

VM 1	$\frac{A}{B} = \frac{2}{4} = .5$	$\rightarrow 1$
VM 2	$\frac{A}{B} = \frac{2}{4} = .5$	$\rightarrow 1$
	Total	2

of SQL Server Standard Processor licenses required

VMs that Will Run SQL Server Web

None

VMs that Will Run SQL Server Workgroup

None

VMs that Will Run SQL Server Enterprise

VM 3	$\frac{A}{B} = \frac{2}{4} = .5$	$\rightarrow 1$
VM 4	$\frac{A}{B} = \frac{4}{4} = 1$	$\rightarrow 1$
	Total	2

C \rightarrow # of physical processors

of SQL Server Enterprise Processor licenses required is LESSER of these

Under the Per Processor model, this server requires:

- Two SQL Server Standard Processor licenses
- Two SQL Server Enterprise Processor licenses
- No CALs

Note: If all four of the physical processors are licensed for SQL Server Enterprise, then the software may be run on as many VMs as the hardware and operating system will support.

EXAMPLE 4.5: CALCULATING PROCESSOR LICENSES FOR MULTIPLE VMs WITH HYPER-THREADING ON

This example server has three single-core processors supporting three VMs running SQL Server (and one VM running Microsoft BizTalk® Server). Hyper-threading is on, so each virtual processor is the equivalent of one thread. Each core has two threads, so there are two threads per processor.

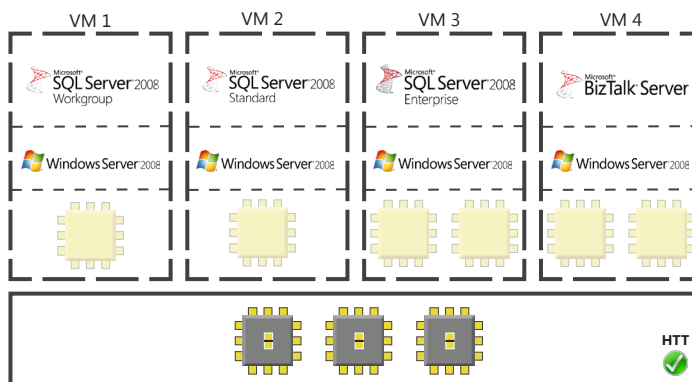

VMs that Will Run SQL Server Standard

Round up to the next whole number

VM 2: $\frac{A}{B} = \frac{1}{2} = .5 \rightarrow 1$

Number of **SQL Server Standard** Processor licenses required

VMs that Will Run SQL Server Web

None

VMs that Will Run SQL Server Workgroup

VM 1: $\frac{A}{B} = \frac{1}{2} = .5 \rightarrow 1$

Number of **SQL Server Workgroup** Processor licenses required

VMs that Will Run SQL Server Enterprise

VM 3: $\frac{A}{B} = \frac{2}{2} = 1$ → C = 3 ← # of physical processors

of **SQL Server Enterprise** Processor licenses required is LESSER of these

Under the Per Processor model, this server requires:

- One SQL Server Standard Processor licenses
- One SQL Server Workgroup Processor licenses
- One SQL Server Enterprise Processor license
- No CALs

Note: If all three of the physical processors are licensed for SQL Server Enterprise, then the software may be run on as many VMs as the hardware and operating system will support.

How to Calculate Processor Licenses for SQL Server Running on VMs and the POSE

In some cases, you may want to run SQL Server on the physical operating system environment (POSE) in addition to running SQL Server on VMs.

If this is the case, you simply calculate the licenses required for the VMs as explained above, and then license the POSE in the same manner as for any physical server as explained in Chapter 3.

Special Consideration for SQL Server Enterprise

If SQL Server Enterprise will run in VMs and the POSE, keep in mind that:

- Under the Server/CAL model, if the physical server is licensed for SQL Server Enterprise, the software may be run in the POSE and any number of VMs the hardware will support.
- Likewise, under the Per Processor model, if all processors are licensed, the software may be run in the POSE and any number of VMs the hardware will support.

Server Application License Mobility: Reassigning Licenses and Moving SQL Server Instances within a Server Farm

For load balancing and dynamic allocation of resources within a server farm, you may want to move instances of SQL Server across servers. **Effective September 1, 2008, Microsoft introduced changes to the license rules for moving instances of server software products across server in a server farm. For SQL Server, these rule changes apply to SQL Server 2008 Enterprise only.**

For other editions, once a SQL Server license is assigned to a specific server, you cannot reassign it to another server and move the running instance of SQL Server within 90 days. To move running instances of SQL Server more often than that, each server would need to have a license assigned to it.



EXAMPLE 4.6: REASSIGNING LICENSES FOR SQL SERVER EDITIONS OTHER THAN SQL SERVER 2008 ENTERPRISE

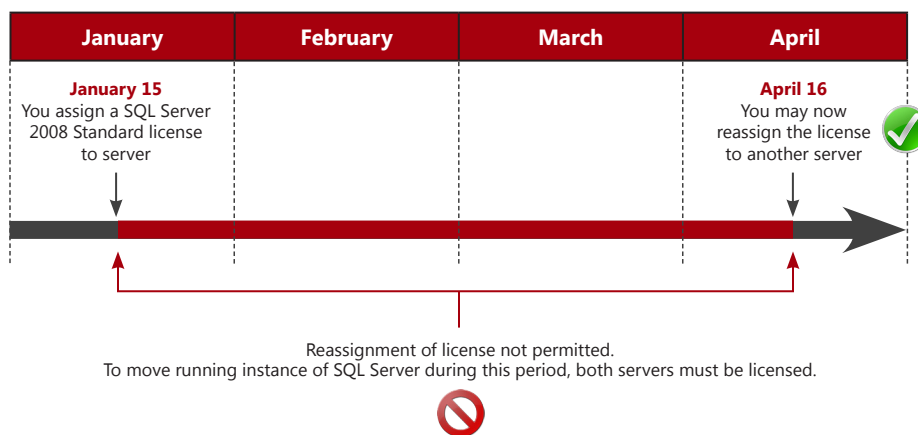

Reassigning Licenses and Moving Running Instances of SQL Server 2008 Enterprise

When properly licensed, running instances of SQL Server 2008 Enterprise may be moved freely across servers within a server farm. (There is no 90 day minimum period before reassignment.)



EXAMPLE 4.7: REASSIGNING SQL SERVER 2008 ENTERPRISE LICENSES WITHIN A SERVER FARM

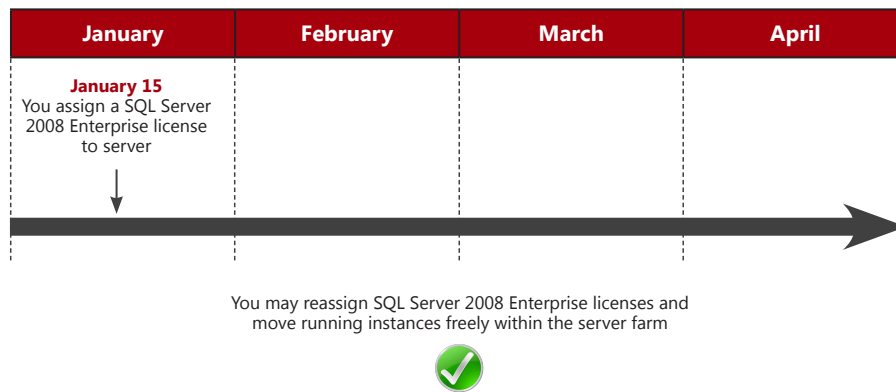

! RULES 4.2: SERVER FARMS

- A server farm can consist of up to two data centers each physically located:
 - In time zones that are within four hours of one another (**UTC is Coordinated Universal Time**), and/or
 - Within the European Union (EU) and/or European Free Trade Association (EFTA)
- Each data center may be part of only one server farm. You may reassign a data center from one server farm to another, but not on a short-term basis (that is, not within 90 days of the last assignment).



EXAMPLE 4.8: SERVER FARM

Data centers A and B can be in the same server farm because their UTC time zones are within four hours of one another. Data Center C and Data Center D cannot be in the same server farm, because their UTC time zones are not within four hours on one another.

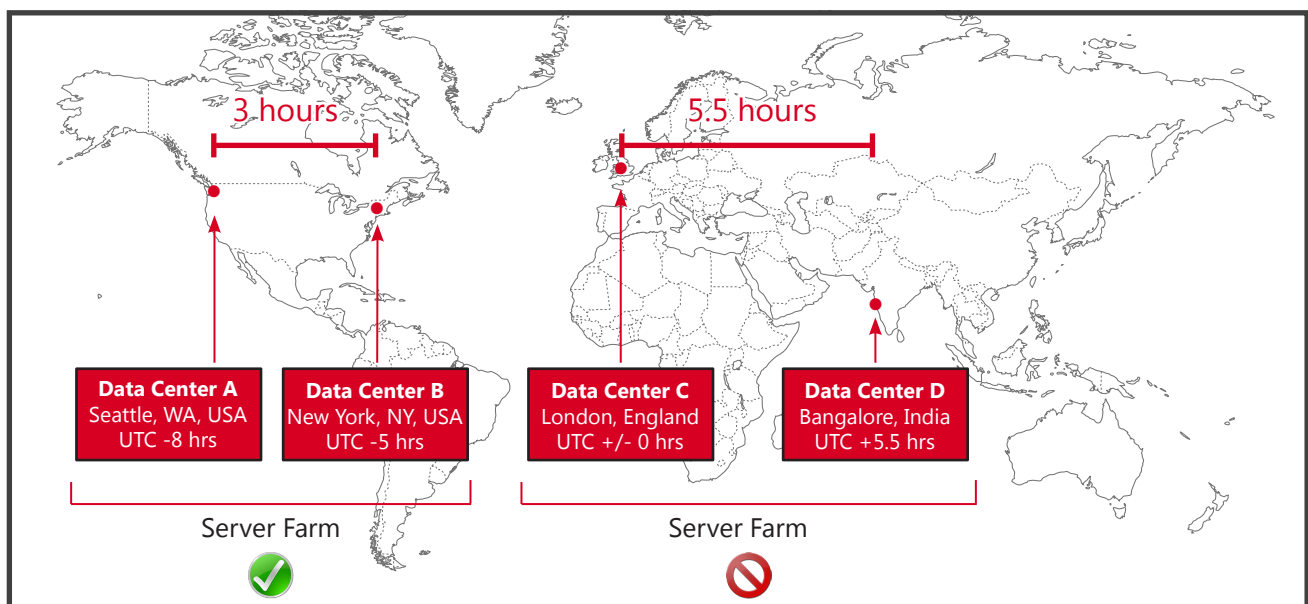

RULES 4.3: MOVING INSTANCES OF SQL SERVER ENTERPRISE IN SERVER FARMS

- Under the Server/CAL model, you may run unlimited instances of SQL Server 2008 Enterprise within the server farm, and move those instances freely, as long as those instances are not running on more servers than the number of licenses assigned to the server farm.
- Under the Per Processor model, you effectively count the greatest number of physical processors that may support running instances of SQL Server 2008 Enterprise at any one time across the server farm and assign that number of Processor licenses (see Diagram 4.7).
- Once a SQL Server 2008 Enterprise license is assigned to a specific server, you cannot be reassign it to another server outside of the server farm and move the running instance of SQL Server instance within 90 days.

DIAGRAM 4.8: COUNTING PROCESSORS LICENSES FOR SERVER APPLICATION MOBILITY SCENARIOS

If you can be sure that only certain physical processors support running instances for SQL Server 2008 Enterprise, then you only need a Processor license for those physical processors.

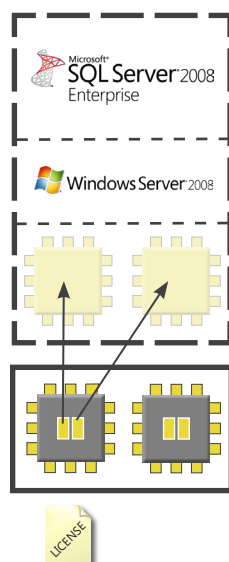

If you are unable to control which physical processor(s) support running instances of SQL Server 2008 Enterprise (or you do not know), then you need a Processor license for each physical processor.

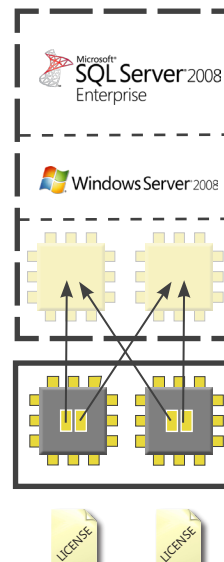



EXAMPLE 4.9: MOVING SQL SERVER 2008 ENTERPRISE INSTANCES ACROSS THREE SERVERS WITHIN A FIVE SERVER FARM

In this example, we have a server farm with five servers. The organization wants to run instances of SQL Server 2008 Enterprise on a single VM on each of any three servers in the farm at any one time.

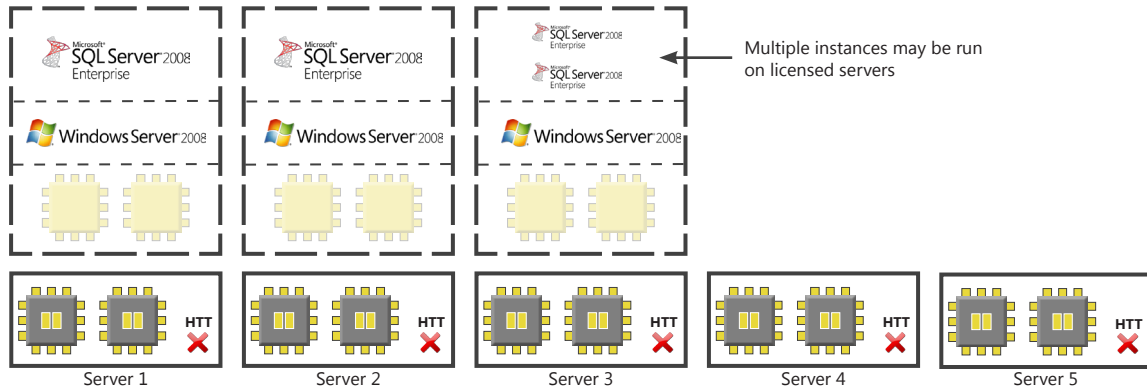

License requirements:

Server/CAL Model	Per Processor Model
<ul style="list-style-type: none"> • Three Server licenses • SQL CALs as required 	<ul style="list-style-type: none"> • Six Processor licenses, or • Three Processor licenses (only if you can be sure that only one physical processor per server is supporting running instances of SQL Server) • No SQL Server CALs required <p><i>Note: Prior to the implementation of the Application Server License Mobility rule, 10 Processor licenses would have been required to achieve the same flexibility.</i></p>

i For more information, refer to the Server Application Mobility licensing brief at <http://www.microsoft.com/licensing/resources/volbrief.mspx>.

Chapter 5: How to Count Licenses in Advanced Scenarios

Part 2: High Availability, Multiplexing, and Components

IN THIS CHAPTER

High Availability/Failover Support	35
Back-up Log Shipping	36
Database Mirroring	39
Failover Clustering	41
Multiplexing/Pooling	43
Using SQL Server Business Intelligence Components on Additional Servers	46
Additional Software That May Be Run	47

KEY TERMS INTRODUCED

Failover: Setting up servers so that if one fails, the other takes over

Multiplexing (pooling): The use of hardware and/or software that reduces the number of devices or users that directly access the server software

High Availability/Failover Support

Microsoft® SQL Server® can be configured so that if one server fails, its processing will be picked-up, recovered, and continued by the other server. SQL Server 2008 Enterprise, Standard, Web, and Workgroup editions provide three types of failover support:

- Backup log-shipping
- Database mirroring
- Failover clustering

Log-shipping and database mirroring take place at the database level, whereas failover clustering takes place at the SQL Server instance level.

i For detailed information about High Availability solutions, visit:
<http://msdn.microsoft.com/en-us/library/cc645993.aspx>.

Each failover type and the licensing requirements are described further below. Regardless of which type of failover support is being used, keep the following rules in mind:

RULES 5.1: FAILOVER BASICS

The server being used for failover does not need to be licensed for SQL Server as long as it is truly "passive" (not serving SQL Server data to clients or running active SQL Server workloads). If it is serving SQL Server data to clients (such as reports) or running active SQL Server workloads, then it must be licensed for SQL Server.

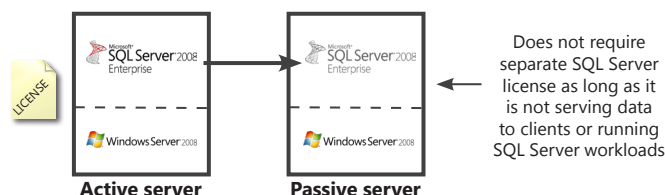

For any operating system environment in which you run instances of the server software, you may run up to the same number of passive failover instances in a separate operating system environment.

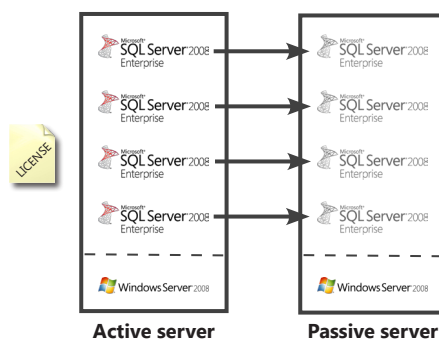

When licensing SQL Server under the Per Processor model, the number of Processor licenses must be based on the server that requires the higher number of licenses. This way, when the failover server takes over, it is adequately licensed.

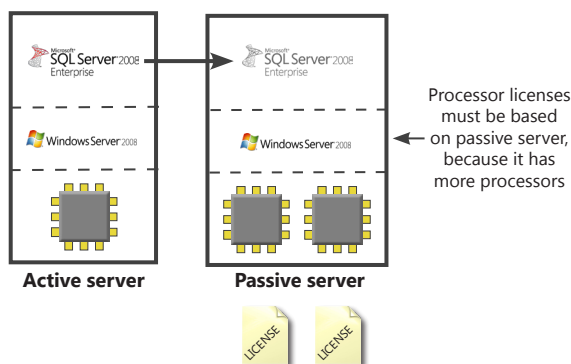

❖ Back-up Log Shipping

Log shipping allows you to automatically send transaction log back-ups from a primary database on a primary server instance to one or more secondary databases on separate secondary server instances. The transaction log backups are applied to each of the secondary databases individually. An optional third server instance, known as the monitor server, records the history and status of back-up and restore operations and, optionally, raises alerts if these operations fail to occur as scheduled.

SQL Server 2008 Standard and Enterprise licenses allow for shipping logs from one primary server instance to one secondary server instance.

? DECISION TREE 5.1: DO I COUNT LICENSES BASED ON THE ACTIVE OR PASSIVE SERVER?

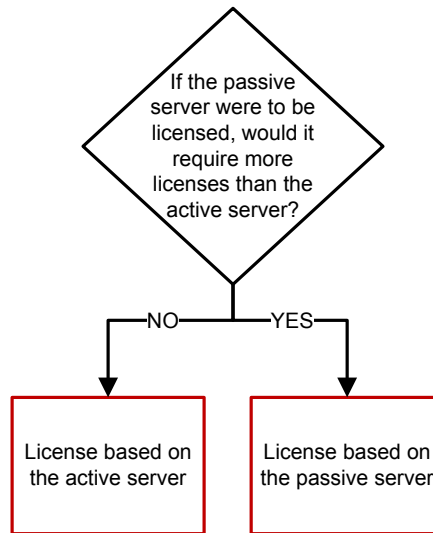

DIAGRAM 5.1: LOG-SHIPPING CONFIGURATION

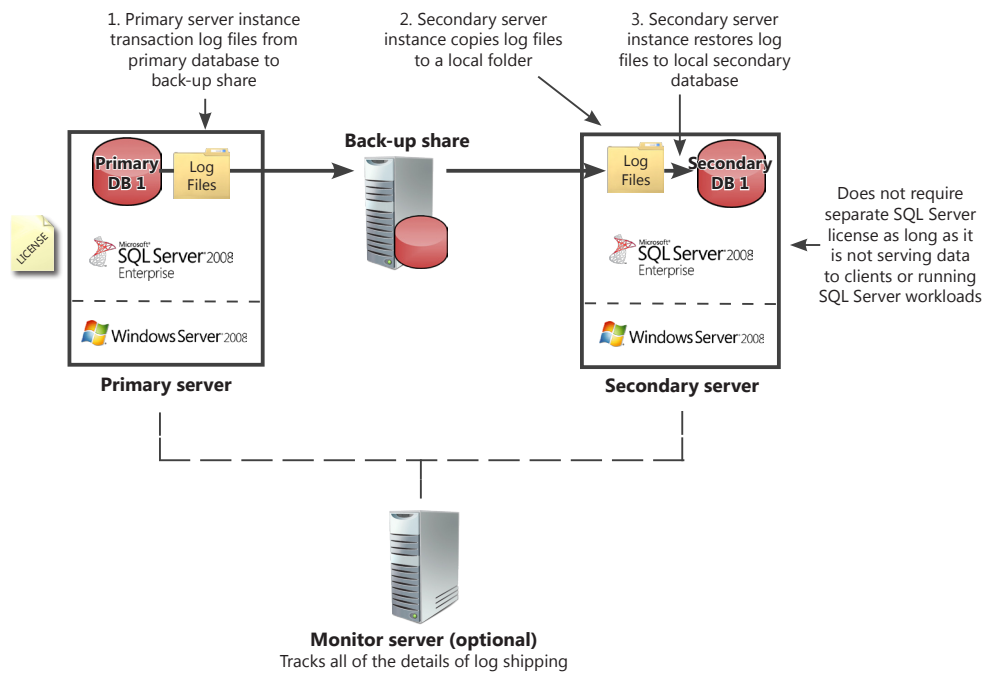

DIAGRAM 5.2: LOG-SHIPPING FROM A SINGLE PRIMARY SERVER TO MULTIPLE SECONDARY SERVERS

Back-up log shipping allows for multiple secondary servers, however, the SQL Server license for the primary server covers only one secondary server. Any additional secondary servers receiving the log file back-ups must be licensed.

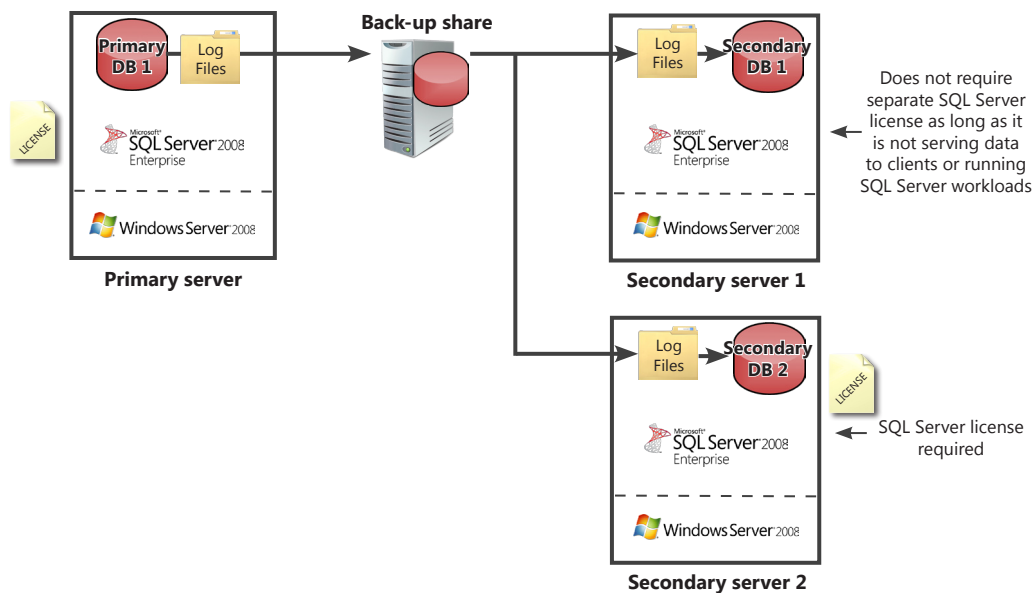
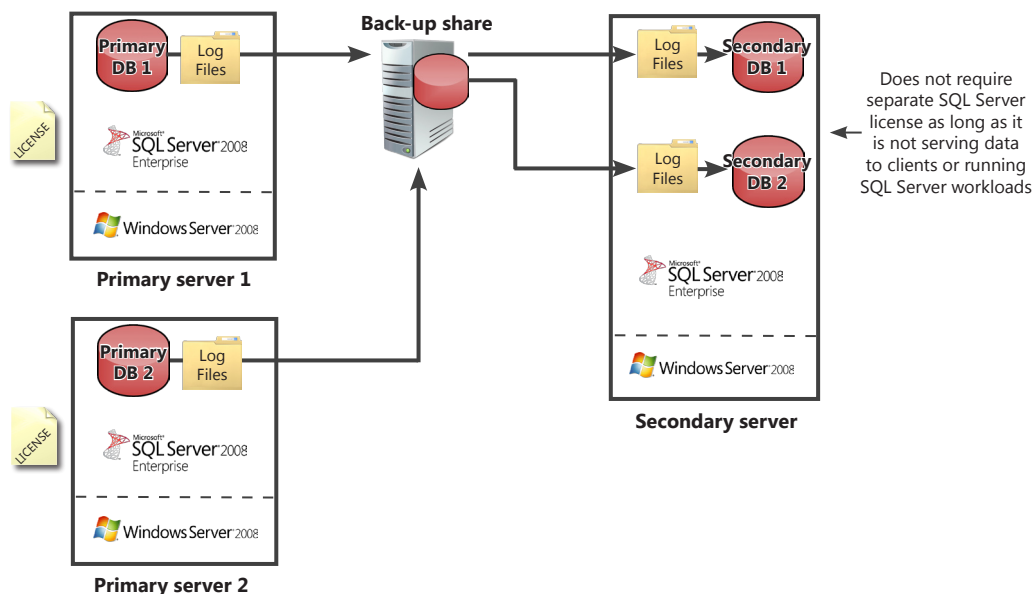

DIAGRAM 5.3: LOG-SHIPPING FROM MULTIPLE PRIMARY SERVERS TO A SINGLE SECONDARY SERVER

A single server may act as the secondary server for multiple primary servers. In this case, each primary server instance may ship back-up logs to the secondary server without the need to license the secondary server for SQL Server.



Database Mirroring

Each database mirroring configuration involves two servers:

- **Principal server:** Contains the principal database and serves the database to clients
- **Mirror server:** Contains the mirror database, which is brought continuously up-to-date with the principal database

 **DIAGRAM 5.4: DATABASE MIRRORING PRINCIPAL AND MIRROR SERVERS**

A single server may act as the secondary server for multiple primary servers. In this case, each primary server instance may ship transaction logs to the secondary server without the need to license the secondary server for SQL Server.

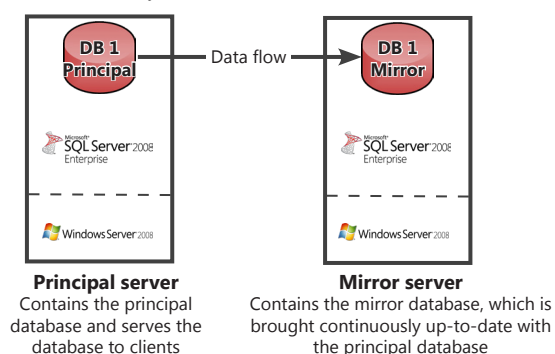

Operation Modes for Database Mirroring

Database mirroring runs with either synchronous operation in high-safety mode, or asynchronous operation in high-performance mode:

- **High-safety mode:** A committed transaction is committed on both servers, but at the risk of increased transaction latency. This mode provides hot standby server that supports rapid failover without a loss of data from committed transactions.
- **High-performance mode:** The transactions commit without waiting for the mirror server to write the log to disk, which maximizes performance. This mode provides a warm standby server (with possible data loss).

High-safety mode with automatic failover requires a third server instance, known as a *witness*. The witness does not serve the database; it supports automatic failover by verifying whether the principal server is up and functioning.

DIAGRAM 5.5: DATABASE MIRRORING CONFIGURATION

A single server may act as the secondary server for multiple primary servers. In this case, each primary server instance may ship transaction logs to the secondary server without the need to license the secondary server for SQL Server.

In the case that the principal server fails, the mirror server takes over as the principal.
 A 30-day grace period is allowed to restore and run SQL Server on the original principal server or license the mirror server (which is now serving as the principal server).

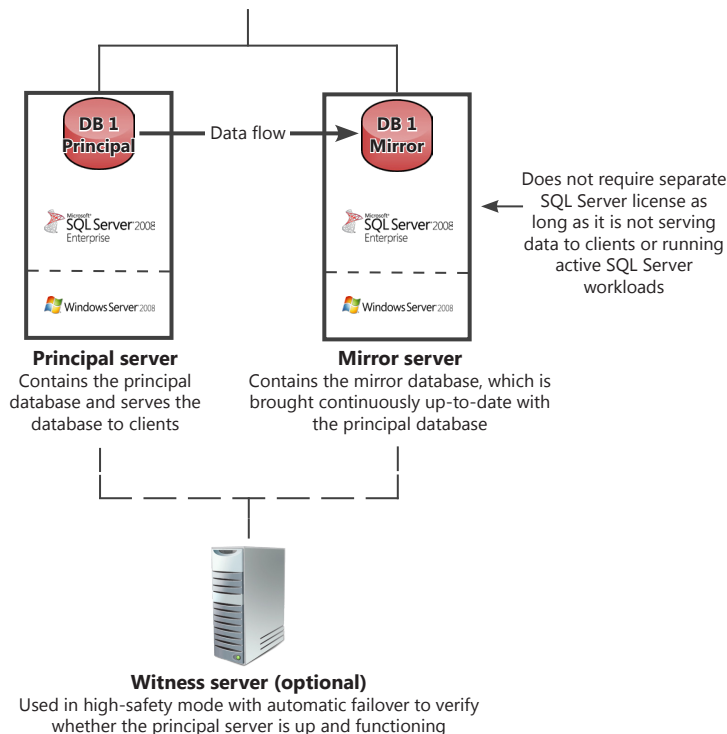

Snapshot Reporting

The mirror may be used indirectly for reporting by creating a database snapshot on the mirror database. The database snapshot provides clients with read-only access to the data in the database as it existed when the snapshot was created. This functionality, however, requires that the Mirror Server be licensed, as the SQL Server data is being accessed.

DIAGRAM 5.6: DATABASE MIRRORING WITH SNAPSHOT REPORTING

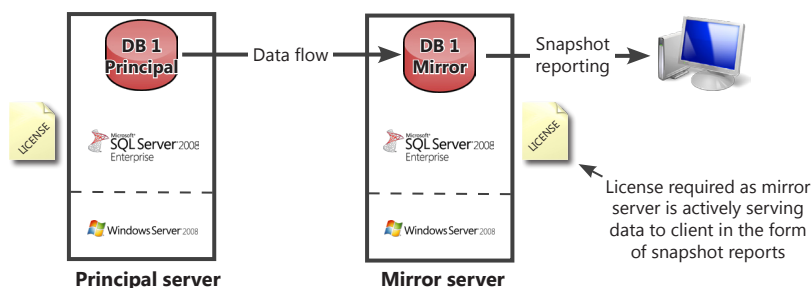

Failover Clustering

Failover clustering provides high-availability support for an entire instance of SQL Server. A failover cluster is a combination of one or more nodes, or servers, with two or more shared disks. SQL Server 2008 Enterprise supports failover clusters with up to 16 nodes. SQL Server 2008 Standard supports 2-node failover clusters.

Note: SQL Server Reporting Services reporting components cannot provide failover support when they are clustered.

DIAGRAM 5.7: 2-NODE AND N+1 FAILOVER CLUSTERS

In a two node cluster, one server (active server) is set-up to failover to the other server (passive server). In an n+1 failover cluster, you have a given number of servers (n) running active SQL Server instances (active servers) all set-up to failover to the same server. In this case the failover (passive) server does not require a separate license because it is not running SQL Server workloads or serving data to clients.

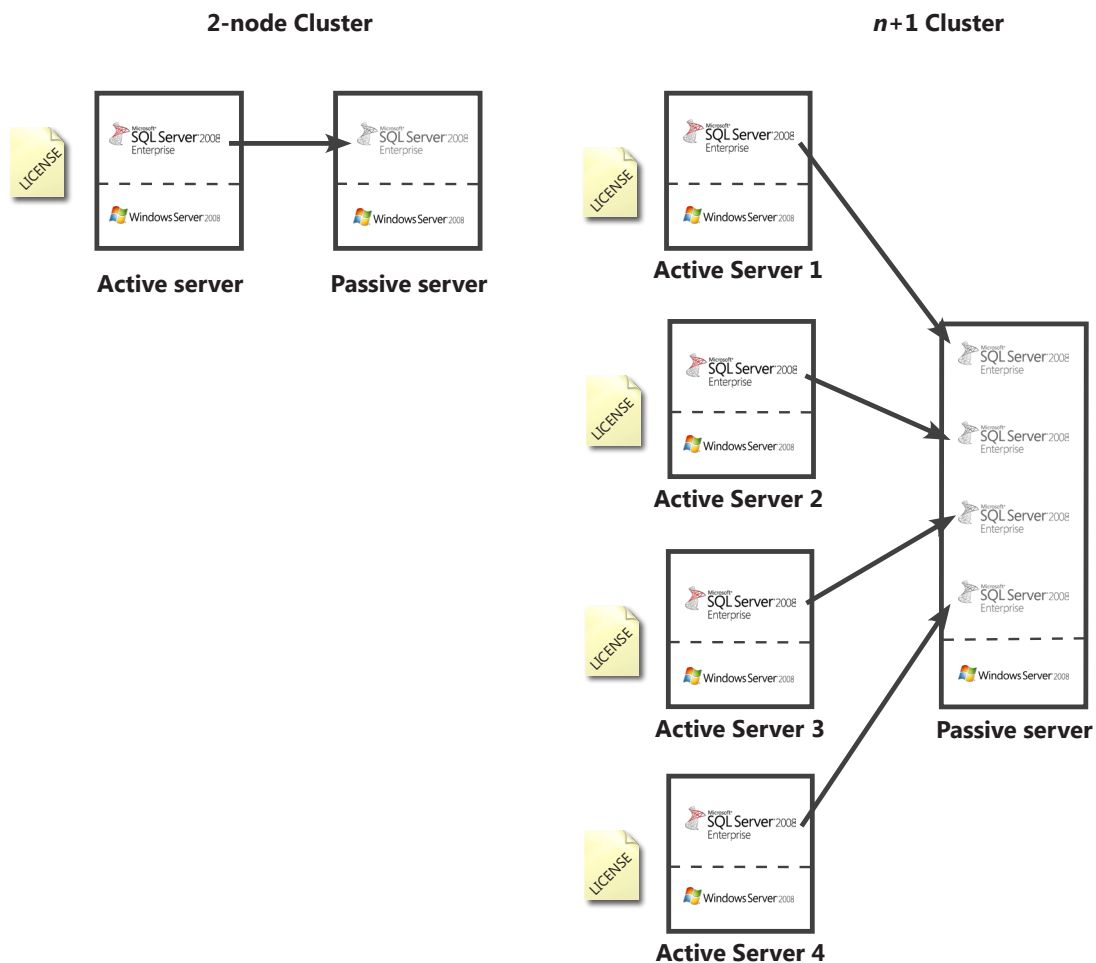

DIAGRAM 5.8: FAILOVER CLUSTER WITH ACTIVE FAILOVER SERVER

In this example, Servers 1-4 are set to failover to Server 5, which is also running an active instance of SQL Server (requiring that it be licensed.) Server 5, in turn, is set to failover to Server 4.

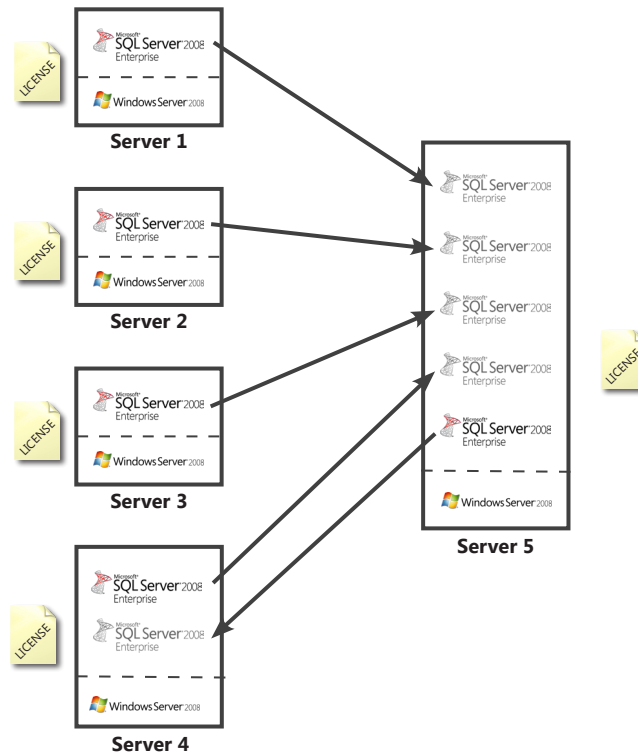
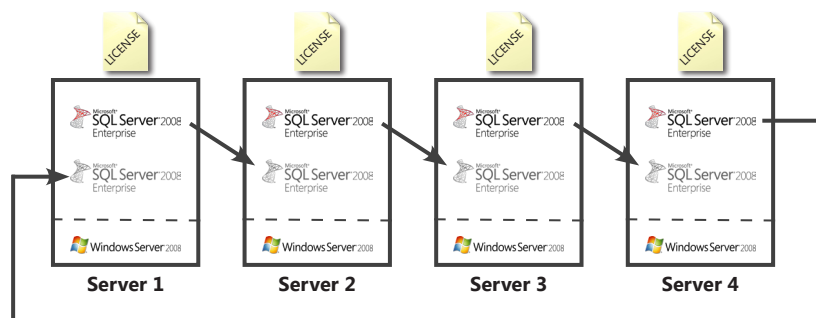

DIAGRAM 5.9: FAILOVER CLUSTER WITH EACH ACTIVE SERVER SET TO FAILOVER TO ANOTHER ACTIVE SERVER

Each server is acting as the failover server for another server in the cluster and also running an active instance of SQL Server, therefore needs to be licensed.



“Cold” Backups for Disaster Recovery

If you have Software Assurance coverage for your SQL Server license are also entitled to the “Cold” Backups for Disaster Recovery benefit. With this benefit, for each instance of SQL Server run in a physical or virtual operating system environment on a licensed server, you may temporarily run a backup instance in a physical or virtual operating system environment on a server dedicated to disaster recovery.

❗ RULES 5.1: “COLD” BACKUPS FOR DISASTER RECOVERY

- The server must be turned off except for (i) limited software self-testing and patch management, or (ii) disaster recovery.
- The server may not be in the same cluster as the production server.
- The backup and production instances may be run at the same time only while recovering the production instance from a disaster.
- The right to run the backup instances ends when the Software Assurance coverage ends.

Multiplexing/Pooling

Sometimes organizations develop network scenarios that use various forms of hardware and/or software that reduce the number of devices or users that directly access or use the software on a particular server, often called “multiplexing” or “pooling” hardware or software. Use of multiplexing or pooling hardware and/or software does not reduce the number of CALs required. *Remember: If licensing under the Per Processor model, CALs are not required.*

! RULES 5.2: MULTIPLEXING

A SQL CAL and Windows Server CAL are required for each distinct device or user that is connected to the multiplexing or pooling software or hardware front end:

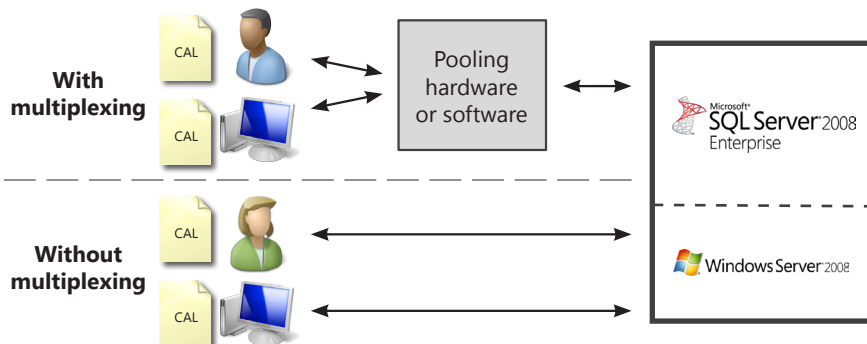

The number of tiers of hardware or software between the SQL Server and the user or devices that ultimately use its data, services, or functionality does not affect the number of CALs required:

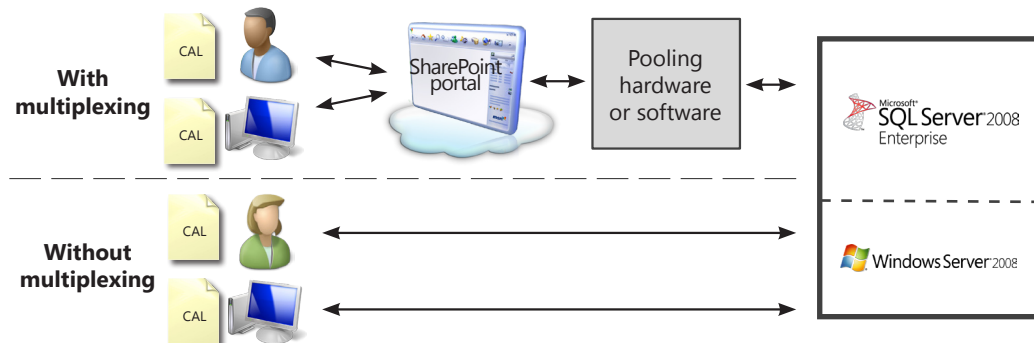

Manual transfer of data from employee to employee does not require a CAL for the receiving employee. For example, if an employee sends a Microsoft Office Excel® version of a report to another employee, the receiving employee does not require a CAL (as long as the report does not access a SQL Server in some way):

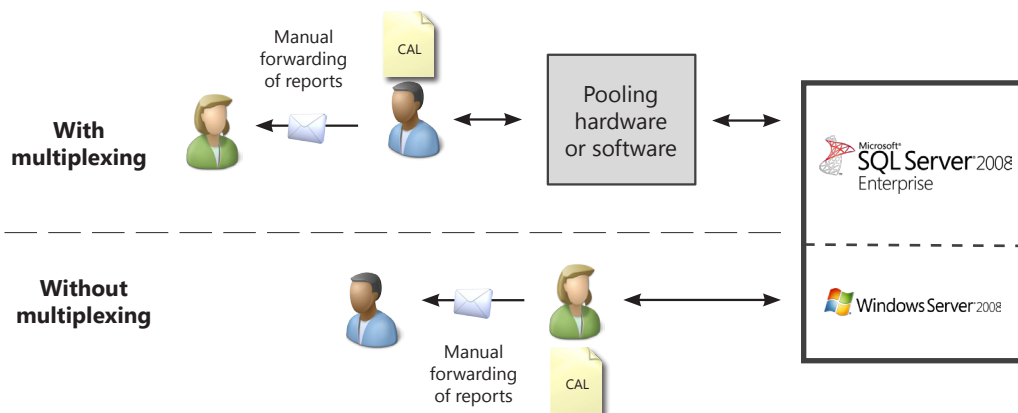

EXAMPLE 5.1: ROBOTIC VEHICLE CONTROL APPLICATION

In this example, taken from an actual customer case, a Microsoft partner has developed a solution for controlling robotic forklifts in a warehouse. This custom application connects directly to SQL Server. The forklifts connect via wireless TCP/IP to the application which directs the vehicles. The application also monitors the forklifts, and if errors occur, that data is written back to SQL Server.

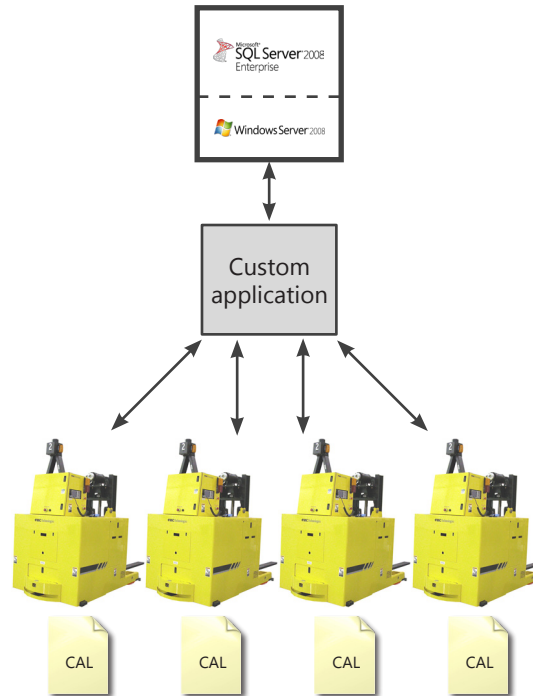

Four SQL Server CALs and four Windows Server CALs are required (although the forklifts connect indirectly to SQL Server data, they still require CALs under the Server/CAL model).

EXAMPLE 5.2: CONNECTING TO SQL SERVER DATA THROUGH OLTP APPLICATION RUNNING ON ORACLE

Even though the users in Group A are not connecting directly to the SQL Server data warehouse, they still require CALs.

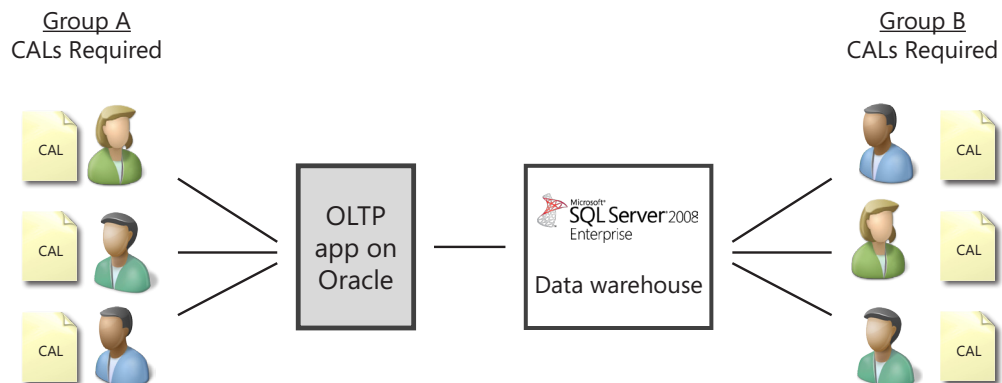

Using SQL Server Business Intelligence Components on Additional Servers

The Business Intelligence components for SQL Server 2008 include Analysis Services (AS), Reporting Services (RS), and Integration Services (IS). To use any of these components, the server on which the component is installed must have a valid SQL Server license. If these components are running on a separate server than the main database server, then they require an additional license for each additional server on which they are installed.

DIAGRAM 5.10: BUSINESS INTELLIGENCE COMPONENT LICENSING

Any server running a SQL Server BI component must be licensed for SQL Server.



EXAMPLE 5.2: SQL SERVER BI COMPONENTS ON DIFFERENT SERVERS

In this example, SQL Server 2008 Enterprise is running on the production server, and SQL Server 2008 Standard Reporting Services and Analysis Services are running on separate servers.

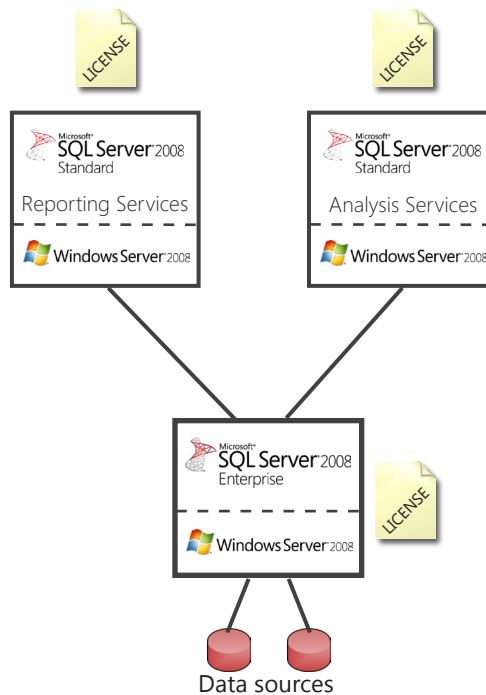

Each server needs to be licensed. If licensing under the Server/CAL model, you would need one SQL Server 2008 Enterprise license and two SQL Server 2008 Standard licenses.

EXAMPLE 5.3: SQL SERVER BI COMPONENTS ON SAME SERVER

In this example, SQL Server 2008 Standard is running on the production server, and SQL Server 2008 Standard Reporting Services and Analysis Services are running on the same separate server.



If licensing under the Server/CAL model, you would need two SQL Server 2008 Standard licenses.

Additional Software That May Be Run

The license rights for SQL Server 2008 Enterprise, Standard, Web, and Workgroup editions permit—**without the need for additional licenses**—the use of the following additional software in any number of virtual or physical operating system environments on any number of devices connecting directly or indirectly to SQL Server:

- Business Intelligence Development Studio
- Client Tools Backward Compatibility
- Client Tools Connectivity
- Client Tools Software Development Kit
- Management Studio
- Microsoft Sync Framework
- SQL Server 2008 Books Online

Chapter 6: Other Microsoft Products that Run on SQL Server

IN THIS CHAPTER

Overview	48
Dynamics ERP	49
Forefront Client Security Management Console	49
Windows SBS and EBS	51
System Center	53

Overview

Some Microsoft® products run on Microsoft SQL Server® for functionality as an enabling technology. In these cases, you often have the option to license SQL Server technology along with the other product license, or to use your separately-acquired SQL Server licenses.

Below is an overview of Microsoft products that use SQL Server as an enabling technology, and your options for acquiring the necessary SQL Server licenses.

TABLE 6.1: HOW TO LICENSE SQL SERVER AS AN ENABLING TECHNOLOGY FOR OTHER MICROSOFT PRODUCTS

Category	SQL Server Licensing Options	Products
1	SQL Server licenses required and must be acquired separately under Server/CAL or Per Processor models	<ul style="list-style-type: none"> Microsoft Dynamics® CRM Microsoft Office SharePoint® Server
2	SQL Server licenses required and may be acquired: <ol style="list-style-type: none"> 1) separately under Server/CAL or Per Processor models, or 2) with product offering that includes SQL Server technology 	<ul style="list-style-type: none"> Dynamics ERP Forefront Client Security Management Console Windows Small Business Server (SBS) Windows Enterprise Business Server (EBS) Microsoft System Center

The remainder of this chapter provides additional guidance for choosing from among the licensing options for products that fall into **Category 2** in the table above. You will find details about specific product offerings below, but generally this is how to decide whether you should choose the product offering that includes SQL Server when available:

DECISION TREE 6.1: DO I CHOOSE THE PRODUCT OFFERING THAT INCLUDES SQL SERVER?

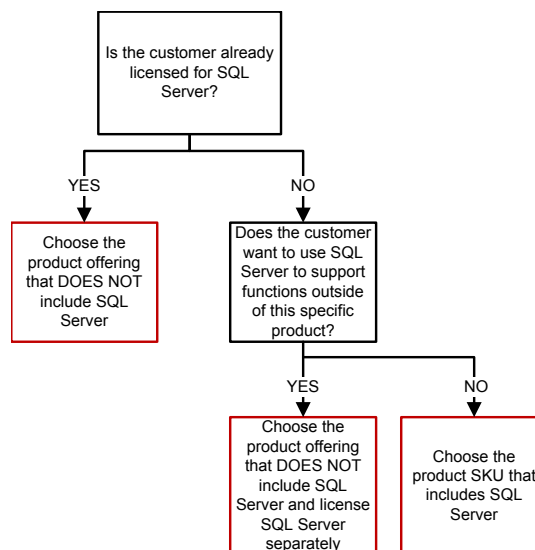

Dynamics ERP

Dynamics ERP—which includes Dynamics AX, Dynamics GP, Dynamics NAV, and Dynamics SL—relies upon SQL Server as an enabling technology.

Options for Licensing SQL Server for Use With Dynamics ERP

If you already have SQL Server licensed, you do not need to acquire additional SQL Server licenses for use with Dynamics ERP.

If you do not have SQL Server licensed, you have the following options for licensing SQL Server with Dynamics ERP:

TABLE 6.2: OPTIONS FOR LICENSING SQL SERVER WITH DYNAMICS ERP

Licensing Options for SQL Server	Separate SQL Server CALs Required?	Notes on SQL Server Use Rights
Acquire Dynamics ERP product and Acquire SQL Server Enterprise or Standard Runtime license for each user	No (Runtime licenses cover users)	SQL Server may be used solely to support the Dynamics product.
Acquire Dynamics ERP product and Acquire SQL Server Enterprise or Standard under <u>Per Processor model</u>	No	SQL Server may be used in accordance with Product Use Rights/Software License Terms for purposes beyond supporting Dynamics ERP product.
Acquire Dynamics ERP product and Acquire SQL Server Enterprise or Standard under <u>Server/CAL model</u>	Yes Requirements: <ul style="list-style-type: none"> SQL Server user CAL for every user using Dynamics ERP or SQL Server device CALs for every device on which Dynamics ERP is installed 	SQL Server may be used in accordance with Product Use Rights/Software License Terms for purposes beyond supporting Dynamics ERP product.

Forefront Client Security Management Console

Forefront Client Security Management Console is available on a per server subscription basis through Microsoft Volume Licensing, **SQL Server is required**.

Options for Licensing SQL Server for Use With Forefront Client Security Management Console

If you already have SQL Server licensed, you should choose Forefront Client Security Management Console without SQL Server.

If you do not have SQL Server licensed, you have the following options for licensing SQL Server with Forefront Client Security Management Console:

TABLE 6.2: OPTIONS FOR LICENSING SQL SERVER WITH FOREFRONT CLIENT SECURITY MANAGEMENT CONSOLE

Licensing Options for SQL Server	Separate SQL Server CALs Required?	Notes on SQL Server Use Rights
Acquire Forefront Client Security Management Console with SQL Server 2005 Technology (Services SL)	No	<ul style="list-style-type: none"> • SQL Server may be used solely to support Forefront Client Security. • You may run, at any one time, one instance in one physical or virtual operating system environment on one server. • You may create and store any number of instances of SQL Server 2005 Technology on any of servers or storage media solely to exercise the right to run an instance of that technology.
Acquire Forefront Client Security Management Console (without SQL Server) and Acquire SQL Server Enterprise or Standard under <u>Per Processor model</u>	No	SQL Server may be used in accordance with Product Use Rights/Software License Terms for purposes beyond supporting Forefront Client Security.
Acquire Forefront Client Security Management Console (without SQL Server) and Acquire SQL Server Enterprise or Standard under <u>Server/CAL model</u>	Yes Requirements: <ul style="list-style-type: none"> • SQL Server user CAL for every user using Forefront Client Security, or • SQL Server device CAL for every device on which Forefront Client Security (the client) and Forefront Client Security Management Console is installed 	SQL Server may be used in accordance with Product Use Rights/Software License Terms for purposes beyond supporting Forefront Client Security.

Windows SBS and EBS

Windows Small Business Server (SBS) 2008 and Windows Essential Business Server (EBS) 2008 are available in two editions: Standard and Premium. The Premium editions include everything in the Standard edition, plus SQL Server 2008 Standard for Small Business¹ and Windows Server[®] 2008 Standard.

¹SQL Server 2005 may be used in place of or in addition to SQL Server 2008 Standard Edition for Small Business subject to the use rights for SBS/EBS 2008 Premium. (All running instances should be in one Microsoft Active Directory[®] domain).

Options for Licensing SQL Server for Use With SBS or EBS

If you who already have SQL Server and Windows Server licensed appropriately, you should choose the Standard Edition of SBS or EBS.

If your do not have SQL Server licensed, you have the following options for licensing SQL Server with SBS:

 **TABLE 6.3: OPTIONS FOR LICENSING SQL SERVER WITH SBS**

Licensing Options for SQL Server	Separate SQL Server CALs Required?	Notes on SQL Server Use Rights
Acquire SBS Premium	No	You may run, at any one time, any number of instances of SQL Server 2008 Standard Edition in one physical or virtual OSE within the Windows SBS 2008 domain (not withstanding any hardware or software limitations).
Acquire SBS Standard and Acquire SQL Server Enterprise or Standard under <u>Per Processor model</u>	No	SQL Server may be used in accordance with Product Use Rights/Software License Terms for purposes beyond supporting SBS.
Acquire SBS Standard and Acquire SQL Server Enterprise, Standard, or Standard for Small Business under <u>Server/CAL model</u>	Yes Requirements: <ul style="list-style-type: none"> • SQL Server user CAL for every user accessing the server, or • SQL Server device CAL for every device accessing the server 	SQL Server may be used in accordance with Product Use Rights/Software License Terms for purposes beyond supporting SBS.
Acquire SBS Standard and Acquire SQL Standard for Small Business under <u>Server/CAL model</u>	Yes Requirements: <ul style="list-style-type: none"> • SQL Server Standard for Small Business user CAL or SQL Server user CAL or for every user accessing the server, or • SQL Server Standard for Small Business device CAL or SQL Server device CAL for every user accessing the server, or • Windows Small Business Server (SBS) 2008 CAL Suite for Premium Users or Devices may be used instead of SQL Server 2008 CALs to access instances of the server software within an SBS domain 	SQL Server Standard for Small Business may be used in accordance with Product Use Rights/Software License Terms for purposes beyond supporting SBS.

If you do not have SQL Server licensed, you have the following options for licensing SQL Server with EBS:

TABLE 6.4: OPTIONS FOR LICENSING SQL SERVER WITH EBS

Licensing Options for SQL Server	Separate SQL Server CALs Required?	Notes on SQL Server Use Rights
Acquire EBS Premium	No	You may run, at any one time, any number of instances of SQL Server 2008 Standard Edition in one physical or virtual OSE within the Windows EBS 2008 domain (not withstanding any hardware or software limitations).
Acquire EBS Standard and Acquire SQL Server Enterprise or Standard under <u>Per Processor model</u>	No	SQL Server may be used in accordance with Product Use Rights/Software License Terms for purposes beyond supporting EBS.
Acquire EBS Standard and Acquire SQL Server Enterprise, Standard, or Standard for Small Business under <u>Server/CAL model</u>	Yes Requirements: <ul style="list-style-type: none"> • SQL Server user CAL for every user accessing the server, or • SQL Server device CAL for every device accessing the server 	SQL Server may be used in accordance with Product Use Rights/Software License Terms for purposes beyond supporting EBS.
Acquire EBS Standard and Acquire SQL Standard for Small Business under <u>Server/CAL model</u>	Yes Requirements: <ul style="list-style-type: none"> • SQL Server Small Business user CAL or SQL Server user CAL or for every user accessing the server, or • SQL Server Small Business device CAL or SQL Server device CAL for every user accessing the server, or • Windows Essential Business Server (EBS) 2008 CAL Suite for Premium Users or Devices may be used instead of SQL Server 2008 CALs to access instances of the server software within an EBS domain 	SQL Server Standard for Small Business may be used in accordance with Product Use Rights/Software License Terms for purposes beyond supporting EBS.

System Center

SQL Server technology is offered with the following Microsoft System Center products:

- System Center Configuration Manager
- System Center Essentials
- System Center Mobile Device Manager
- System Center Operations Manager
- System Center Data Protection Manager (always includes SQL Server)

Options for Licensing SQL Server for Use With System Center

If you already have SQL Server licensed, you should choose the System Center product offering that does not include SQL Server.

If you do not have SQL Server licensed, you have the following options for licensing SQL Server with System Center products:

TABLE 6.5: OPTIONS FOR LICENSING SQL SERVER WITH SYSTEM CENTER PRODUCTS

Licensing Options for SQL Server	Separate SQL Server CALs Required?	Notes on SQL Server Use Rights
Acquire System Center product that <u>includes</u> SQL Server (e.g. System Center Configuration Manager with SQL Server 2005 Technology)	No	SQL Server may be used solely to support the specific System Center product (e.g. System Center Configuration Manager).
Acquire System Center Configuration Manager product that <u>does not include</u> SQL Server and Acquire SQL Server Enterprise or Standard under <u>Per Processor model</u>	No	SQL Server may be used in accordance with Product Use Rights/Software License Terms for purposes beyond supporting the specific System Center product.
Acquire System Center Configuration Manager product that <u>does not include</u> SQL Server and Acquire SQL Server Enterprise or Standard under <u>Server/CAL model</u>	Yes Requirements: <ul style="list-style-type: none"> • SQL Server user CAL for every user with a device, or devices, managed by the System Center product, or • SQL Server device CAL for every device managed by the System Center product 	SQL Server may be used in accordance with Product Use Rights/Software License Terms for purposes beyond supporting the specific System Center product.

Chapter 7: Upgrades, Downgrades, and Step-ups

IN THIS CHAPTER

Overview	54
Version Upgrades	55
Version Downgrades	55
Edition Step-ups	56
Step-up Pricing	56

KEY TERMS INTRODUCED

- Downgrade:** Move to a previous version of the software (e.g. from SQL Server 2008 to SQL Server 2005)
- Step-up:** Move from a lower edition to a higher edition of the software (e.g. from SQL Server Standard to SQL Server Enterprise)
- Upgrade:** Move to a newer version of the software (e.g. from SQL Server 2005 to SQL Server 2008)

Overview

Diagram 7.1 provides an overview of the version upgrade, version downgrade, and edition step-up paths for the Workgroup, Standard, and Enterprise editions of Microsoft® SQL Server® 2008 and 2005. Further details follow.

DIAGRAM 7.1: UPGRADE, DOWNGRADE, AND STEP-UP PATHS

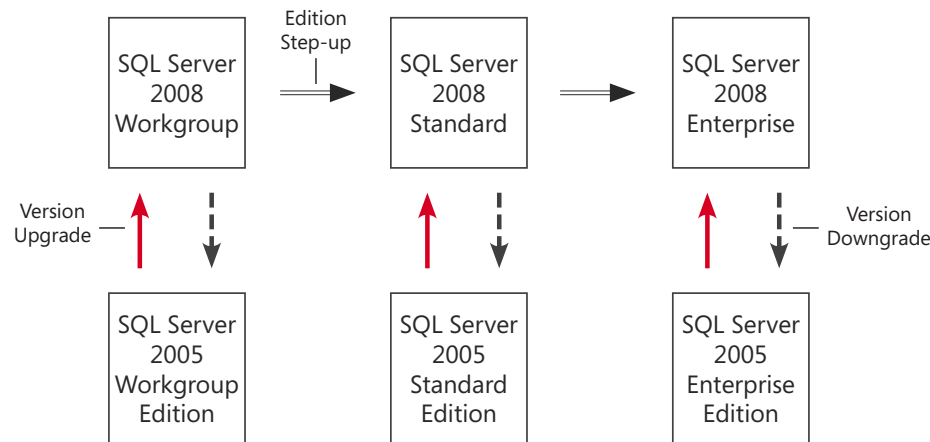

	What it Means	How to Get It
Version Upgrade	Move from previous version (e.g. SQL Server 2005) to current version (e.g. SQL Server 2008)	<ol style="list-style-type: none"> If existing SQL Server license is covered by SA, you are automatically licensed for upgrade to corresponding SQL Server 2008 edition If existing SQL Server license is not covered by SA, you must purchase a new full license for SQL Server 2008 edition you want
Version Downgrade	Deploy earlier version in place of currently-licensed version (per terms of Software License Terms/PUR)	Downgrade Rights granted for: <ul style="list-style-type: none"> All licenses acquired through Microsoft Volume Licensing OEM and FPP (retail) versions of SQL Server Enterprise, Standard, and Workgroup
Edition Step-Up	Move from lower edition (e.g. Standard) to higher edition (e.g. Enterprise)	<ul style="list-style-type: none"> Lower edition must be covered by Software Assurance (SA) You acquire the SA Step-Up SKU offered through certain Volume Licensing programs Step-ups available from Workgroup to Standard or Standard to Enterprise

Version Upgrades

With a version upgrade, you move from a previous version of the software (e.g. Microsoft® SQL Server® 2005) to a newer version of the software (e.g. SQL Server 2008). The diagram below shows the acceptable paths for upgrading from SQL Server 2005 editions to SQL Server 2008 editions.

⚠️ RULES 7.1: VERSION UPGRADES

- **Cross-version upgrades:** Cross-version instances of SQL Server 2008 are not supported. Version numbers of the Database Engine, Analysis Services, and Reporting Services components must be the same in an instance of SQL Server 2008.
- **Cross-platform upgrades:** Cross-platform upgrade is not supported. You cannot upgrade a 32-bit instance of SQL Server to native 64-bit. However, you can upgrade a 32-bit instance of SQL Server to the WOW64: the 32-bit subsystem on a 64-bit server as noted in the diagram above. You can also back up or detach databases from a 32-bit instance of SQL Server, and then restore or attach them to an instance of SQL Server (64-bit) if the databases are not published in replication. In this case, you must also re-create any logins and other user objects in master, msdb, and model system databases.
- **Failover upgrades:** To upgrade an instance of SQL Server to a SQL Server failover cluster, the instance being upgraded must be a failover cluster.
- **Upgrading on Windows Server 2008 machines:** To upgrade SQL Server 2005 to SQL Server 2008 on a computer that is running Windows Server 2008, you must be running SQL Server 2005 SP2. SQL Server 2005 SP1 is not a supported upgrade scenario.

❓ DECISION TREE 7.1: HOW DO I UPGRADE?

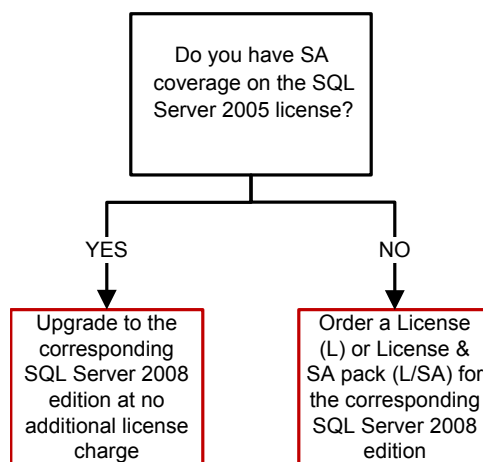

Version Downgrades

You can acquire SQL Server licenses and run prior versions of SQL Server per the downgrade rights outlined in the Software License Terms and/or Product Use Rights (PUR). In other words, if you are licensed for a SQL Server 2008 edition, you may choose to deploy a corresponding SQL Server 2005 edition in its place.

⚠️ RULES 7.2: VERSION DOWNGRADES

- If the earlier version includes different components, any terms for those components in the agreement that comes with the earlier version apply.
- Microsoft is not obligated to supply earlier versions.
- At any time, you may replace an earlier version with your licensed newer version of the software.

Edition Step-ups

With edition step-ups, you move from a lower edition of the product to a higher edition. For SQL Server, Step-up licenses are available to migrate from:

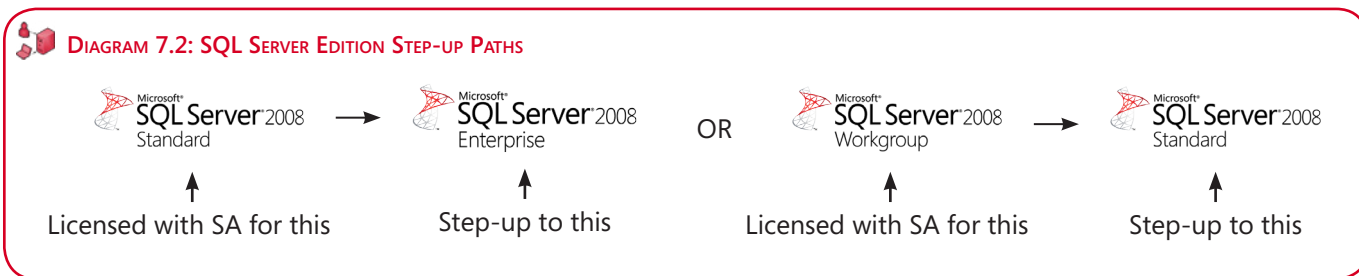

Step-up Pricing

The Step-up License price is the difference between the L/SA price of the higher edition and the L/SA price of the lower edition of the product. To accommodate customers stepping-up at different points in their agreement period, Step-up license SKUs are available for customers with one, two, or three years of SA coverage remaining.

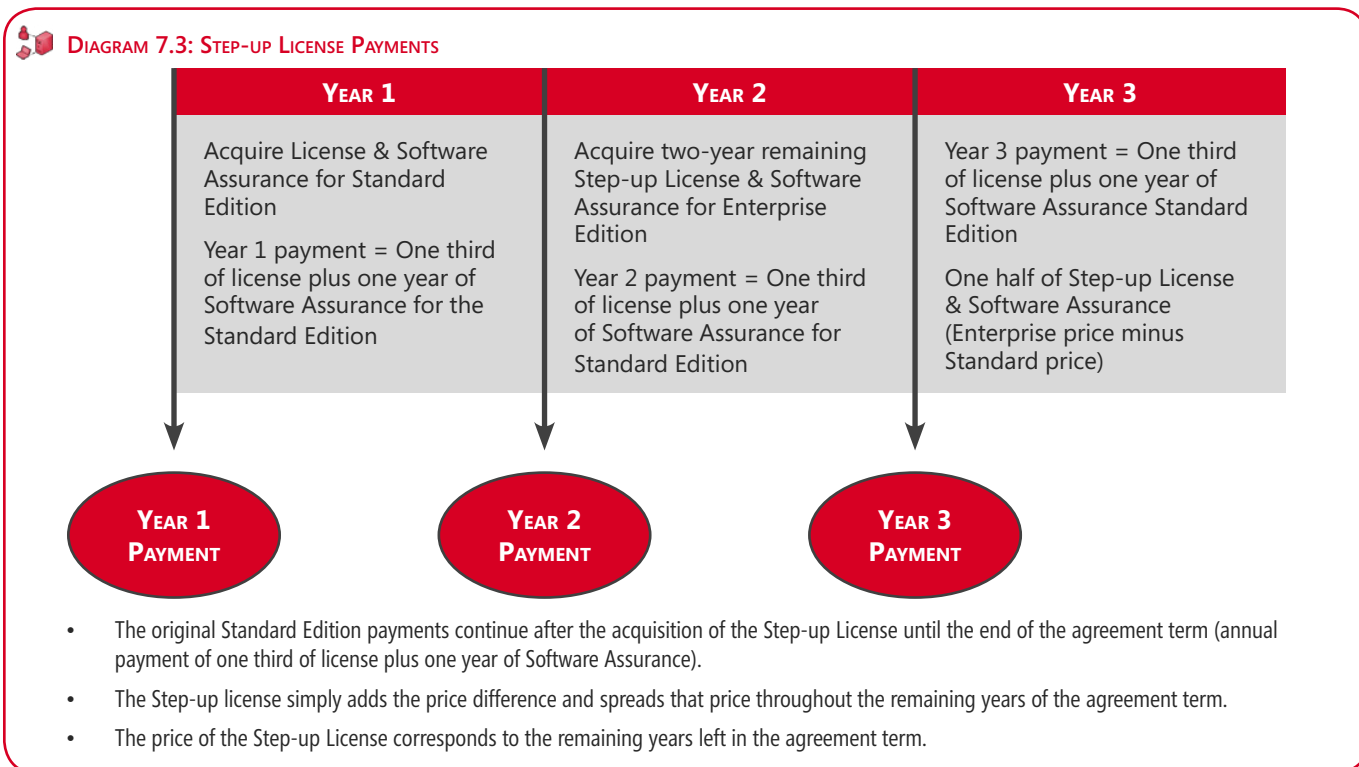

Chapter 8: Software for Evaluation, Development, Training, and Demos

IN THIS CHAPTER

Evaluation and Free Editions	57
Evaluation and Training Use Rights for Volume Licensing Customers	58
Demos, Videos, and Virtual Labs	58

Evaluation and Free Editions

There are three editions of Microsoft® SQL Server® 2008 that are targeted toward evaluation and/or development and available for free.

TABLE 8.1: EVALUATION AND FREE EDITIONS OF SQL SERVER 2008

Edition	What is It?	How to Get It
SQL Server 2008 Enterprise Evaluation	<ul style="list-style-type: none"> Evaluation copy of SQL Server 2008 Enterprise for evaluation purposes only Can be used for up to 180 days 	Order DVD (U.S. only) for download for free at: http://www.microsoft.com/sqlserver/2008/en/us/trial-software.aspx
SQL Server 2008 Express	<ul style="list-style-type: none"> Free edition of SQL Server that is ideal for learning and building desktop and small server applications, and for redistribution by ISVs Available in SQL Server 2008 Express with Advanced Services, SQL Server 2008 Express with Tools, and Server 2008 Express (Runtime Only) editions 	Download for free at: http://www.microsoft.com/sqlserver/2008/en/us/express.aspx
SQL Server 2008 Compact	Entry-level and learning database that can be used to build stand-alone and occasionally connected applications for mobile devices, desktops, and Web clients on all Microsoft Windows platforms	Download for free at: http://www.microsoft.com/sql/editions/compact/downloads.msp

TABLE 8.3: PERMITTED USES BY EDITION

SQL Server Edition	Development	Testing	Internal Demos	Staging	Production
Enterprise Evaluation	•	•	•	•	
Developer/MSDN Subscription	•	•	•	•	
Express	•	•	•	•	•
Compact	•	•			•
Enterprise, Standard, Web & Workgroup	•	•	•	•	•

Evaluation and Training Use Rights for Volume Licensing Customers

As part of the rights granted through their Microsoft Volume Licensing agreement, some customers are entitled to copies of the software for evaluation and training purposes. Those rights are outlined below:

TABLE 8.3: EVALUATION AND TRAINING USE RIGHTS FOR VOLUME LICENSING

Use Right	What it Permits	Eligible Programs
Copies for evaluation	Run up to 10 complimentary copies of any product for a 60-day evaluation period	<ul style="list-style-type: none"> • Campus Agreement • School Agreement • Enterprise Agreement • Enterprise Subscription Agreement • Select License • Select Plus
Copies for training	Run up to 20 complimentary copies of any product in a dedicated training facility on licensed customer's premises	<ul style="list-style-type: none"> • Enterprise Agreement • Enterprise Subscription Agreement • Select License • Select Plus

Demos, Videos, and Virtual Labs

To help you explore the features and benefits of SQL Server, demos, videos, and virtual labs are available online at:

- Demos and videos: <http://www.microsoft.com/sqlserver/2008/en/us/demos.aspx>
- Virtual labs: <http://www.microsoft.com/sqlserver/2008/en/us/virtual-labs.aspx>

Chapter 9: Media Fulfillment

IN THIS CHAPTER

Media Fulfillment

59

KEY TERMS INTRODUCED

Comprehensive Kit: Media kit sent to qualifying Volume Licensing customers at the beginning of their agreement term containing CD-ROMs and/or DVD-ROMs with installation files for licensed products

Fulfillment: Distribution of installation software bits to licensed users

Subscription Kit: Media kit sent to qualifying Volume Licensing customers quarterly containing updates and upgrades of their licensed products

Media Fulfillment

The table below provides an overview of how you receive your licensed Microsoft® SQL Server® products.

TABLE 9.1: MEDIA FULFILLMENT

	Physical Media	Electronic Media
FPP	Boxed product shipped to customer upon placing software order from online retailer	
Volume Licensing	For qualifying customers ¹ who elect to receive physical media: <ul style="list-style-type: none"> Initial media kit² (Comprehensive Kit/Starter Kit/Welcome Kit) with licensed products shipped to customer Updates and upgrades sent to licensed customers quarterly via Subscription Kit² All customers licensed via Volume Licensing can order media for individual licensed products through their reseller	Customers can access Downloads via Volume License Service Center (VLCS) at http://www.microsoft.com/licensing/servicecenter
SPLA	Media for licensed products shipped to Service Provider	Download via VLCS at http://www.microsoft.com/licensing/servicecenter
ISV	Media for licensed products shipped to ISV	
OEM	OEM orders via OEM Distributor and distributes with hardware to customer	OEMs can download the SQL Server Standard for Small Business OEM Preinstallation Kit (OPK) via http://oem.microsoft.com/
MSDN		Download via http://msdn.microsoft.com
TechNet		Download via http://technet.microsoft.com

¹Open License, Open Volume, Open Business, Open License for Academic, Open License for Charity, and Open License for Government customers do not qualify to receive Comprehensive Kits or Subscription kits.

²Refer to the Microsoft Volume Licensing Fulfillment Users Guide Web site at <http://selectug.mslicense.com/> for details on kit contents.

Chapter 10: Pricing and Additional Resources

IN THIS CHAPTER

Pricing Tool	60
SQL Server Licensing and Sales Assistance	60
Resources on the Web	60

Pricing Tool

You can use the Microsoft License Advisor at <http://www.microsoft.com/licensing/mlahome.mspx> to generate estimated price quotes based on Volume Licensing Program and product:

SQL Server Licensing and Sales Assistance

If you need assistance beyond what is provided in this guide for determining the appropriate licensing requirements for a customer scenario, contact your Microsoft account manager or the Microsoft business desk.

Resources on the Web

- SQL Server 2008 Licensing Web Site: <http://www.microsoft.com/sqlserver/en/us/licensing.aspx>
- SQL Server 2008 Pricing Web Site: <http://www.microsoft.com/sqlserver/2008/en/us/pricing.aspx>
- Volume Licensing Briefs: <http://www.microsoft.com/licensing/resources/volbrief.mspx>
- Application Server License Mobility Brief: http://download.microsoft.com/download/3/d/4/3d42bdc2-6725-4b29-b75a-a5b04179958b/Application_Server_License_Mobility_VL_Brief.doc
- Step-Up Licensing White paper: http://download.microsoft.com/download/a/6/9/a69a4aa0-717a-4f73-bbcd-9d7451fddbcb/stepup_license_v4.doc